



# RIDESHARE PAYLOAD USER'S GUIDE

October 2022

## COPYRIGHT

Subject to the existing rights of third parties, Space Exploration Technologies Corp. (SpaceX) is the owner of the copyright in this work, and no portion hereof is to be copied, reproduced, or disseminated without the prior written consent of SpaceX.

No U.S. Export Controlled Technical Data or Technology.

---



## TABLE OF CONTENTS

<b>1</b>	<b>INTRODUCTION</b>	<b>1</b>
1.1	Rideshare Payload User's Guide Purpose	1
1.2	Company Description	2
1.3	Rideshare Program Overview	2
1.4	Falcon 9 Program	3
1.5	Pricing	3
<b>2</b>	<b>PERFORMANCE</b>	<b>4</b>
2.1	Mass Properties	4
2.2	Launch Windows	4
2.3	Separation Attitude and Accuracy	5
2.4	Separation Rates and Velocity	5
2.5	Payload Maneuvers and Deployments	6
<b>3</b>	<b>ENVIRONMENTS</b>	<b>7</b>
3.1	Transportation Environments	7
3.2	Cleanroom Environments	7
3.3	Flight Environments	8
3.3.1	Payload Natural Frequencies and Damping	8
3.3.2	Payload Design Load Factors	8
3.3.3	Sine Vibration	10
3.3.4	Acoustic	10
3.3.5	Shock	12
3.3.6	Random Vibration	12
3.3.7	Electromagnetic	13
3.3.8	Fairing Internal Pressure	15
3.3.9	Payload Temperature Exposure During Flight	15
3.3.10	Free Molecular Heating	16
3.3.11	Payload Conductive Boundary Temperatures	16
3.3.12	Contamination	17
3.4	Environmental Verification Testing	18
3.4.1	Verification Approach	18
3.4.2	Documentation Requirements	19
3.4.3	Payload Unit Test Levels	20
3.4.4	Fully Containerized CubeSat Unit Test Levels	21
3.4.5	Functional Testing Requirements	22
3.4.6	Qualification - No Test Considerations	22



<b>4</b>	<b>PAYLOAD DESIGN AND INTERFACE.....</b>	<b>23</b>
4.1	Payload Design Requirements .....	23
4.1.1	Design Factors of Safety .....	23
4.1.2	Fasteners.....	23
4.1.3	Cable Ties.....	23
4.1.4	Pressure Vessels.....	23
4.1.5	Fully Integrated Pressure systems.....	25
4.2	Mechanical Interfaces.....	27
4.2.1	Launch Vehicle Coordinate Frame .....	27
4.2.2	Launch Vehicle Fairing.....	27
4.2.3	Payload Coordinate Frame .....	28
4.2.4	Standard Mechanical Interfaces.....	28
4.2.5	Payload Available Volume.....	28
4.2.6	Mechanical Interface Compatibility .....	33
4.3	Electrical Interface .....	33
4.3.1	Standard Offering Interface .....	33
4.3.2	Deployment Channel Properties .....	34
4.3.3	Breakwire Channel Properties .....	34
4.3.4	Umbilical Channel Properties .....	35
4.3.5	Flight Harness Design.....	36
4.3.6	Connectivity during Payload Processing.....	36
4.3.7	Ground Harness Design.....	36
4.3.8	Timing Services.....	37
4.3.9	Electrical Interface Compatibility.....	37
<b>5</b>	<b>LAUNCH SITE FACILITIES.....</b>	<b>38</b>
5.1	Facility Access and Working Hours.....	38
5.2	Customer Offices .....	38
5.3	SpaceX Payload Processing Facility (PPF).....	38
5.4	Launch Complex .....	39
5.5	Launch Countdown Monitoring.....	39
<b>6</b>	<b>MISSION INTEGRATION AND SERVICES.....</b>	<b>40</b>
6.1	Contracting.....	40
6.2	US Export and Import Control Laws.....	40
6.3	Mission Management .....	40
6.4	Program Documentation .....	41
6.4.1	Interface Control Document (ICD).....	41



6.4.2	Launch Campaign Plan.....	41
6.4.3	Program Status, Meetings, Working Groups and Reviews.....	41
6.5	Customer Responsibilities .....	41
6.5.1	Transportation.....	41
6.5.2	Hardware, Processing and Integration.....	42
6.5.3	Hazardous Procedures .....	42
6.5.4	Entry and Exit Visas.....	43
6.5.5	Anomaly, Mishap, Accident or Other Event .....	43
6.5.6	Payload Licensing and Registration.....	43
6.5.7	Coordination with Space Situational Awareness Agencies.....	43
6.6	SpaceX Responsibilities .....	43
6.6.1	Launch Scheduling .....	43
6.6.2	Transportation Services .....	44
6.6.3	Payload Integration and Associated Hardware .....	44
6.6.4	Photographic Services.....	44
6.6.5	Security .....	44
6.6.6	Launch Campaign.....	44
6.6.7	Facility Support and Operations .....	44
6.6.8	Licensing and Registration .....	45
6.6.9	Mission Integration Analyses .....	45
<b>7</b>	<b>OPERATIONS.....</b>	<b>47</b>
7.1	Overview and Schedule.....	47
7.2	Rideshare Payload Delivery and Transportation.....	47
7.3	Rideshare Payload Processing.....	47
7.4	Joint Operations and Integration.....	47
7.5	Launch Operations.....	47
7.5.1	Organization.....	47
7.5.2	Launch Control.....	48
7.5.3	Rollout and Pad Operations.....	48
7.5.4	Countdown.....	48
7.5.5	Recycle and Scrub.....	48
7.6	Flight Operations.....	48
<b>8</b>	<b>SAFETY.....</b>	<b>49</b>
8.1	Safety Requirements.....	49
8.2	Hazardous Systems and Operations .....	49
8.3	Waivers.....	49



---

APPENDIX A: MECHANICAL INTERFACES AND VOLUMES .....	50
APPENDIX B: PAYLOAD DYNAMIC MODEL REQUIREMENTS.....	62
APPENDIX C: PAYLOAD CAD MODEL REQUIREMENTS.....	65
APPENDIX D: PAYLOAD ENCAPSULATION & LAUNCH READINESS CERTIFICATES.....	66
APPENDIX E: DELIVERY FORMAT OF SEPARATION STATE VECTOR.....	68
APPENDIX F: PAYLOAD LICENSING CERTIFICATION .....	69
APPENDIX G: DELIVERABLES DESCRIPTION .....	70
APPENDIX H: PAYLOAD CONSTITUENTS .....	75
APPENDIX I: OPTIONAL SERVICES.....	76
APPENDIX J: DEFINITIONS.....	77



## ACRONYMS

AFSPCMAN	Air Force Space Command Manual
AIAA	American Institute of Aeronautics and Astronautics
ATM	acceleration transformation matrix
CAD	computer-aided design
CCSFS	Cape Canaveral Space Force Station
CG	center of gravity
CLA	coupled loads analysis
CSLA	Commercial Space Launch Act
CSpOC	Combined Space Operations Center
DRM	data recovery matrix
DTM	displacement transformation matrix
EAR	export administration regulations
ECEF	earth-centered, earth-fixed
EGSE	electrical ground support equipment
EIRP	equivalent isotropically radiated power
EMI	electromagnetic interference
EMISM	EMI safety margin
ETFE	ethylene tetrafluoroethylene
FAA	Federal Aviation Administration
FCC	Federal Communications Commission
FEM	finite element model
GN2	gaseous nitrogen
GOP	ground operations plan
GPS	global positioning system
GSE	ground support equipment
HVAC	heating, ventilation and air conditioning
ICD	interface control document
IGES	initial graphics exchange specification
IRIG	inter-range instrumentation group
ITAR	international traffic in arms regulations
KSC	Kennedy Space Center
LOX	liquid oxygen
LTM	load transformation matrix
LV	Launch Vehicle
LVLH	local vertical/local horizontal
MDP	maximum design pressure
MEOP	maximum expected operating pressure
MPE	maximum predicted environment
MPT	maximum and minimum predicted temperatures
MSPSP	missile system prelaunch safety package
NASA	National Aeronautics and Space Administration



NASTRAN .....NASA Structural Analysis

OASPL .....overall sound pressure level

OPM .....orbital parameter message

OTM .....output transformation matrix

P&ID .....piping and instrumentation diagram

PI .....program Introduction

PL .....Payload

PPF .....payload processing facility

Q .....dynamic pressure

RE .....radiated emissions

RF .....radio frequency

RMS .....root-mean-square

RP-1 .....rocket propellant-1 (rocket-grade kerosene)

RS .....radiated susceptibility

RSS .....root sum squared

RTV .....room temperature vulcanizing

Rx .....Payload receiver(s)

SCAPE .....self-contained atmospheric protective ensemble

sccs .....standard cubic centimeter per second

SLC .....space launch complex

SpaceX .....Space Exploration Technologies Corp.

SPCS .....Space Control Squadron

SPL .....sound pressure level

SRS .....shock response spectrum

SSPP .....system safety program plan

STEP .....standard for the exchange of product model data

TAA .....technical assistance agreement

TE .....transporter-erector

Tx .....Payload transmitter(s)

US DOT .....United States Department of Transportation

US .....United States

USD .....United States Dollar

USSPACECOM .....United States Space Command

UTC .....coordinated universal time

VC-HS .....visibly clean – highly sensitive

VSFB .....Vandenberg Space Force Base



## LIST OF FIGURES

Figure 1-1: Example Mission Configuration using Rideshare Plates.....	1
Figure 1-2: Typical Rideshare Program Schedule .....	3
Figure 2-1: Allowable Payload Mass and X <sub>PL</sub> Center of Gravity .....	4
Figure 2-2: Payload +X <sub>PL</sub> Surface Exit Requirement (red) for Rideshare Plate Configuration .....	5
Figure 2-3: Payload +X <sub>PL</sub> Surface Exit Requirement (red) for Starlink Adapter Configuration.....	5
Figure 3-1: Rideshare Plate Payload Design Load Factors.....	9
Figure 3-2: Starlink Adapter Payload Design Load Factors .....	10
Figure 3-3: Maximum Predicted Acoustic Environment .....	11
Figure 3-4: Payload Mechanical Interface Shock .....	12
Figure 3-5: Random Vibration MPE .....	13
Figure 3-6: In-Flight & Environmental Radiated Emissions / Payload Radiated Susceptibility Limit.....	14
Figure 3-7: Maximum Fairing Spot Temperature Seen by Rideshare Payload.....	16
Figure 3-8: Bounding Conductive Boundary Temperature .....	16
Figure 4-1: Launch Vehicle Coordinate Frame.....	27
Figure 4-2: Total Available Fairing Volume .....	27
Figure 4-3: Rideshare Plates - Hexagon Configuration (Left) and Cube Configuration (Right).....	28
Figure 4-4: Rideshare Plate – ¼ Plate Available Volume .....	29
Figure 4-5: Rideshare Plate – ½ Plate Available Volume .....	29
Figure 4-6: Rideshare Plate – Full Plate Available Volume.....	30
Figure 4-7: Rideshare Plate – Full Plate including Internal Available Volume .....	30
Figure 4-8: Rideshare Plate – Full Plate (XL Volume) Available Volume .....	31
Figure 4-9: Rideshare Plate – Full Plate (XL Volume) including Internal Available Volume.....	31
Figure 4-10: Rideshare Plate – Example CubeSat Dispenser Available Volume.....	32
Figure 4-11: Starlink Adapter - 15" Diameter Payload Available Volume .....	32
Figure 4-12: Starlink Adapter 24" Diameter Payload Available Volume .....	33
Figure 4-13: Illustration of Breakwire Channel Categories .....	35
Figure 4-14: Ground Side Electrical Interfaces.....	37
Figure 6-1: Mission Management Organization.....	40
Figure A-1: 8" Diameter Mechanical Interface.....	50
Figure A-2: 15" Diameter Mechanical Interface .....	51
Figure A-3: 24" Diameter Mechanical Interface .....	52
Figure A-4: Rideshare Plate - 1/4 Plate Available Volume.....	53
Figure A-5: Rideshare Plate - 1/2 Plate Available Volume.....	54
Figure A-6: Rideshare Plate - Full Plate Available Volume .....	55
Figure A-7: Rideshare Plate - Full Plate including Internal Available Volume.....	56
Figure A-8: Rideshare Plate - Full Plate (XL Volume) Available Volume.....	57
Figure A-9: Rideshare Plate - Full Plate (XL Volume) including Internal Available Volume .....	58
Figure A-10: Rideshare Plate - CubeSat Dispenser Available Volume.....	59
Figure A-11: Starlink Adapter - 15" Diameter Mechanical Interface Available Volume .....	60
Figure A-12: Starlink Adapter - 24" Diameter Mechanical Interface Available Volume .....	61





## LIST OF TABLES

Table 2-1: Launch Vehicle Rates Before Payload Separation .....	6
Table 3-1: Temperature and Cleanliness Environments .....	7
Table 3-2: CubeSat Dispenser (including CubeSats) Design Load Factors.....	8
Table 3-3: Maximum Predicted Sinusoidal Vibration Environment .....	10
Table 3-4: Third Octave Acoustic MPE .....	11
Table 3-5: Full Octave Acoustic MPE .....	11
Table 3-6: Payload Mechanical Interface Shock.....	12
Table 3-7: Random Vibration MPE .....	13
Table 3-8: Launch Vehicle Radiated Emissions .....	14
Table 3-9: Launch Site Radiated Emissions .....	14
Table 3-10: Maximum Payload Emissions.....	15
Table 3-11: Dedicated Rideshare Mission Transmitter Delay Time (seconds).....	15
Table 3-12: Secondary Rideshare Mission Transmitter Delay Time (seconds).....	15
Table 3-13: Bounding Conductive Boundary Temperature and Conductance .....	16
Table 3-14: Payload Contamination Requirements .....	17
Table 3-15: Payload Unit Test Levels and Durations .....	20
Table 3-16: Containerized CubeSat Unit Test Levels and Durations .....	21
Table 4-1: Standard Offering Interface - Maximum Channel Allocation .....	34
Table 4-2: PL-side breakwire resistance requirements .....	35
Table 4-3: Umbilical Channel Electrical Properties.....	35
Table 4-4: Payload Electrical Interface Connectivity.....	36
Table 4-5: Maximum Expected Cable Lengths between Payload EGSE and Payload Electrical Bulkhead.....	36
Table G-1: SpaceX Deliverables Description.....	70
Table G-2: Customer Deliverables Description.....	72
Table H-1: Payload Constituent Details.....	75
Table I-1: Optional Services.....	76



## CHANGE LOG

Date	Update
03 December 2019	Original Release
29 January 2020	Updated Definitions
16 June 2020	<p>General Updates</p> <ul style="list-style-type: none"><li>• Added distinctions between dispenser ring and Starlink rideshares</li><li>• General cleanup and clarification</li></ul> <p>Section 2</p> <ul style="list-style-type: none"><li>• Mass versus C.G. definition updated</li><li>• Clarifications on deployment direction</li><li>• Updated CubeSat and multi-deploy velocities</li><li>• Updated Launch Vehicle pre-separation rates</li></ul> <p>Section 3</p> <ul style="list-style-type: none"><li>• Updated cleanroom environments</li><li>• Updated combined loads including clarification on random vibration interaction</li><li>• Updated transition mass to 225 kg</li><li>• Updated random vibration requirement</li><li>• Updated EMI section – clean up and clarification on TX timelines</li><li>• Updated payload unit test and durations including updated notes</li></ul> <p>Section 4</p> <ul style="list-style-type: none"><li>• Clarification on Mechanical Interface Rings and allowable Payload volume</li><li>• New Payload volume images</li><li>• Additional details added to Electrical Interface</li><li>• Added Launch configuration battery status requirements</li></ul> <p>Appendix A</p> <ul style="list-style-type: none"><li>• Updated Mechanical Interface Ring and volume drawings</li></ul> <p>Appendix D</p> <ul style="list-style-type: none"><li>• Included Encapsulation Readiness Letter Template</li><li>• Updated Launch Readiness Letter Template</li></ul> <p>Appendix G</p> <ul style="list-style-type: none"><li>• Clean up for consistency with SpaceX Rideshare Terms &amp; Conditions</li></ul> <p>Appendix J</p> <ul style="list-style-type: none"><li>• Additional definitions</li></ul>
22 November 2020	<p>General Updates</p> <ul style="list-style-type: none"><li>• Updated acronym list</li></ul> <p>Section 2</p> <ul style="list-style-type: none"><li>• Revised approach on separation requirements</li></ul> <p>Section 3</p> <ul style="list-style-type: none"><li>• Updated Loads, Sine-Vibe, EMI, and thermal MPE sections</li><li>• Added modifications for containerized CubeSats and metallic structures to Section 3.4</li><li>• Added sine-vibe testing approach to Section 3.4</li></ul> <p>Section 4</p> <ul style="list-style-type: none"><li>• Updated Section 4.1.5 volume allowable inside the side-mounted dispenser port interface</li><li>• Added umbilical specifications in Section 4.2 and minor updates</li></ul> <p>Section 6</p> <ul style="list-style-type: none"><li>• Updated separation analysis definition</li></ul> <p>Appendix A</p> <ul style="list-style-type: none"><li>• Figures A-5 and A-6 updated volume allowable inside the side-mounted dispenser port interface</li></ul> <p>Appendix B</p> <ul style="list-style-type: none"><li>• Refined dynamics model definition</li></ul> <p>Appendix G</p> <ul style="list-style-type: none"><li>• Updated deliverables</li></ul> <p>Appendix H</p> <ul style="list-style-type: none"><li>• Export classification no longer required</li></ul> <p>Appendix J</p> <ul style="list-style-type: none"><li>• Additional definitions</li></ul>



Date	Update
29 September 2021	<p>General Updates</p> <ul style="list-style-type: none"><li>• Updated acronym list</li></ul> <p>Section 1</p> <ul style="list-style-type: none"><li>• Added Rideshare program overview description</li></ul> <p>Section 2</p> <ul style="list-style-type: none"><li>• Updated approach for separation rates and velocity</li><li>• Added post-separation Payload maneuvering requirements</li></ul> <p>Section 3</p> <ul style="list-style-type: none"><li>• Updated Loads and Sine Vibration requirements</li><li>• Simplified Acoustics, Shock, and Random Vibration requirements description</li><li>• Combined in-flight and pre-flight emissions into single section</li><li>• Converted transmitter turn on time equation into look up tables dependent on mission type</li><li>• Payloads must wait until "End of Mission" to transmit in certain frequency bands</li><li>• EMI safety margin included in Payload emissions requirement</li><li>• Removed lightning protection/re-test information</li><li>• Revised thermal requirements</li><li>• Updated maximum fairing spot temperature profile</li><li>• Added documentation requirements for environmental verification</li><li>• Split test levels and durations into default, containerized CubeSat, and metallic structure Payload Constituents</li><li>• Updated all test levels and duration tables and their corresponding notes</li><li>• Added functional testing requirements</li></ul> <p>Section 4</p> <ul style="list-style-type: none"><li>• Updated Mechanical Interface Ring design and specifications</li><li>• Fully revised and updated electrical interface section</li><li>• SpaceX responsible for providing deployment signals to all Payload Constituents deploying from the Launch Vehicle</li><li>• Added mechanical and electrical interface compatibility description</li></ul> <p>Section 6</p> <ul style="list-style-type: none"><li>• Updated descriptions on meetings, reviews, and milestones</li><li>• Added Section 6.5.7 for Customer on-orbit coordination</li><li>• Launch Vehicle wet dress rehearsals may be performed with encapsulated Rideshare Payloads attached to the Launch Vehicle</li><li>• Removed fairing venting analysis as a standard SpaceX deliverable</li></ul> <p>Appendices</p> <ul style="list-style-type: none"><li>• A - Updated Mechanical Interface Ring drawings</li><li>• C - Updated acceptable model types</li><li>• E - Included example of post-separation multi-payload OPM</li><li>• G - Updated deliverables descriptions to match SOW updates</li><li>• I - Added insurance optional service</li><li>• J - Added to definitions list</li></ul>
15 March 2022	Updated pricing to reference rideshare website
10 June 2022	<p>General Updates</p> <ul style="list-style-type: none"><li>• Updated acronym list</li></ul> <p>Section 1</p> <ul style="list-style-type: none"><li>• Clarified Payload versus Payload Constituent, multiple deployments, and debris mitigation</li></ul> <p>Section 3</p> <ul style="list-style-type: none"><li>• Added mission safety statement</li><li>• Purpose and verification statements added to each applicable section</li><li>• Design loads updated</li><li>• Sine vibration updated and changed to advised</li><li>• Shock changed to advised</li><li>• Random vibration updated</li><li>• Additional non-metallic materials added to no-fly list</li><li>• Section 3.4 - environmental verification revised to include:<ul style="list-style-type: none"><li>○ Fully integrated testing definition</li><li>○ Allowable disassembly after testing</li><li>○ Removed "metallic materials" testing table</li></ul></li></ul>



Date	Update
	<ul style="list-style-type: none"><li>○ Revised test levels and durations tables</li><li>○ Clarified definition of a fully containerized CubeSat</li><li>○ Additional notes added regarding pressure system testing</li><li>○ Added Section 3.4.6</li></ul> Section 4 <ul style="list-style-type: none"><li>● Added Payload design requirements for factors of safety, fasteners, cable ties, pressure systems and pressure vessels</li></ul>
07 October 2022	Section 1 <ul style="list-style-type: none"><li>● Introduction of Rideshare Plates replacing Rideshare Dispenser Rings</li><li>● Introduction of direct mount CubeSat dispenser and 8" diameter mechanical interface offering</li><li>● Orbital disposal 5 year rule added</li></ul> Section 2 <ul style="list-style-type: none"><li>● Updated allowable masses</li><li>● Secondary deployments must be controlled</li></ul> Section 3 <ul style="list-style-type: none"><li>● Minimum Payload natural frequency and damping updates/clarification</li><li>● Design load factors introduced for CubeSats</li><li>● Design load factors updated for MicroSats and SmallSats<ul style="list-style-type: none"><li>○ Primary bending mode frequency range requirement added</li><li>○ Port lateral loads application guidelines added</li><li>○ Refined mass buckets</li></ul></li><li>● Assumptions added for the development of the shock MPE</li><li>● Non-metallic materials clarified as "each individual"</li><li>● Section 3.4 – environmental verification revised to include<ul style="list-style-type: none"><li>○ Test-like-you-fly exceptions added</li><li>○ Post integrated testing guidance updated</li><li>○ Separation system qualification guidelines added</li><li>○ System-level and vessel-level pressure leak testing added to test tables</li></ul></li></ul> Section 4 <ul style="list-style-type: none"><li>● Fastener requirements updated</li><li>● Cable ties requirements updated</li><li>● Type 5 pressure vessels changed to "use is not recommended"</li><li>● Fluid restriction added for Type 4 and Type 5 pressure vessels</li><li>● Pressure vessel leak testing details added for all pressure vessel types</li><li>● Clarification for definition of pressure system</li><li>● Pressure system leak testing details added</li><li>● Material compatibility requirements added</li><li>● Details added for mechanical interface of Rideshare Plates</li><li>● Details added for electrical interface of Rideshare Plates</li><li>● All umbilical access post Payload stand-alone operations changed to an optional service</li></ul> Appendices <ul style="list-style-type: none"><li>● A - Drawings updated for standard mechanical interfaces and Rideshare Plates</li><li>● B - Dynamics model requirements simplified</li><li>● C - CAD model verification checklist added and requirement to match mass properties</li><li>● D - Updated to match Payload umbilical access option change</li><li>● G - Updated to match revised Rideshare SOW</li><li>● H - Added delivery-on-orbit user details</li><li>● I - Updated to match Payload umbilical access option change</li></ul>

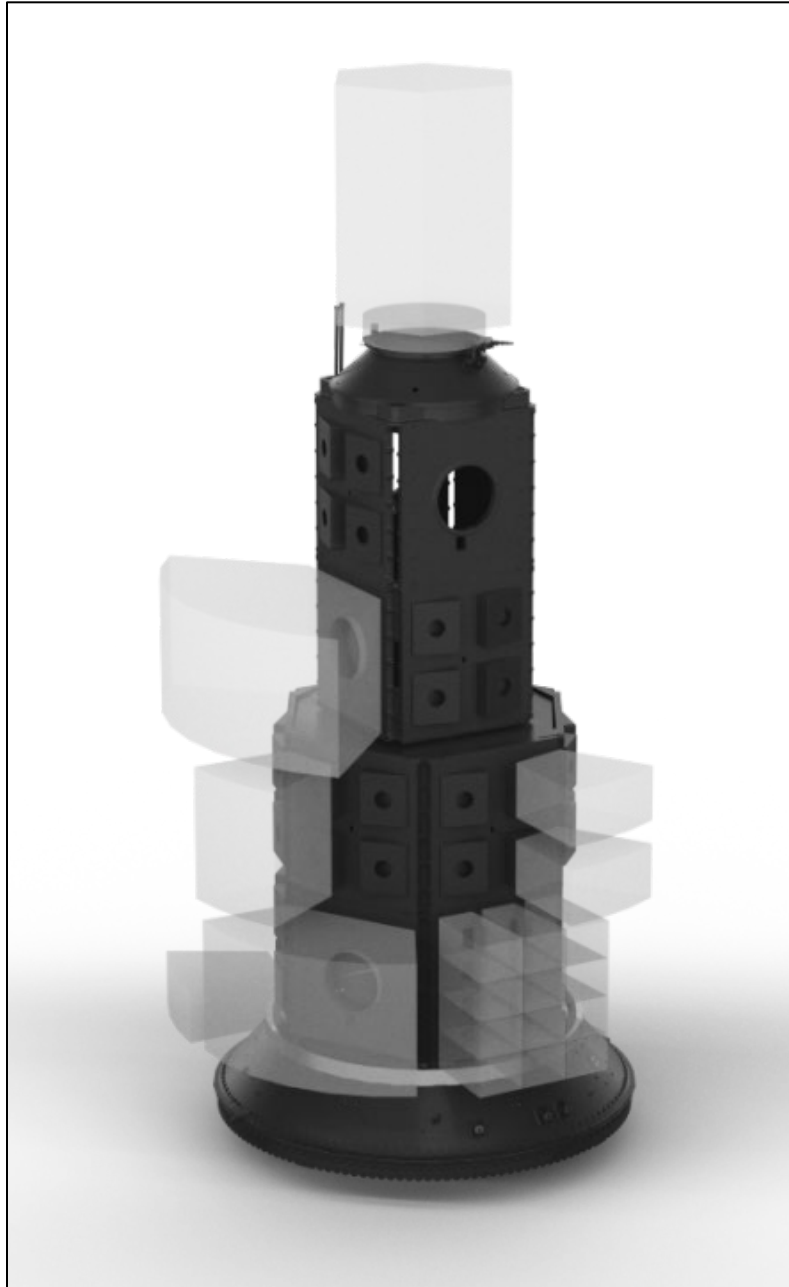


# 1 INTRODUCTION

## 1.1 RIDESHARE PAYLOAD USER'S GUIDE PURPOSE

The Rideshare Payload User's Guide is a planning document provided for small satellite customers of SpaceX (Space Exploration Technologies Corp.). This document is intended to help Rideshare Launch Customers understand SpaceX's standard services for pre-contract Mission planning and to delineate Customer requirements for contracted Rideshare Launch Services.

SpaceX reserves the right to update this guide as required. Future revisions are likely as SpaceX continues to gather additional data and works to improve the Rideshare program.



**Figure 1-1: Example Mission Configuration using Rideshare Plates**



## 1.2 COMPANY DESCRIPTION

SpaceX offers a family of Launch Vehicles that improves launch reliability and increases access to space. The company was founded on the philosophy that simplicity, reliability and cost effectiveness are closely connected. We approach all elements of Launch Services with a focus on simplicity to both increase reliability and lower cost. The SpaceX corporate structure is flat and business processes are lean, resulting in fast decision-making and product delivery. SpaceX products are designed to require low-infrastructure facilities with little overhead, while vehicle design teams are co-located with production and quality assurance staff to tighten the critical feedback loop. The result is highly reliable and producible Launch Vehicles with quality embedded throughout the process.

Established in 2002 by Elon Musk, the founder of Tesla Motors, PayPal and the Zip2 Corporation, SpaceX has developed and flown the Falcon 1 light-lift Launch Vehicle, the Falcon 9 medium-lift Launch Vehicle, the Falcon Heavy heavy-lift Launch Vehicle, the most powerful operational rocket in the world by a factor of two, and Dragon, which is the first commercially produced spacecraft to visit the International Space Station.

SpaceX has built a launch manifest that includes a broad array of commercial, government and international customers. In 2008, NASA selected the SpaceX Falcon 9 Launch Vehicle and Dragon spacecraft for the International Space Station Cargo Resupply Services contract. NASA has also awarded SpaceX contracts to transport astronauts to space as well as to launch scientific satellites. In addition, SpaceX services the National Security community and is on contract with the Air Force for multiple missions on the Falcon family of Launch Vehicles.

SpaceX has state-of-the-art production, testing, launch and operations facilities. SpaceX design and manufacturing facilities are conveniently located near the Los Angeles International Airport. This location allows the company to leverage Southern California's rich aerospace talent pool. The company also operates cutting-edge propulsion and structural test facilities in Central Texas, along with Launch Sites in Florida and California, and the world's first commercial orbital Launch Site in development in South Texas.

## 1.3 RIDESHARE PROGRAM OVERVIEW

SpaceX offers Rideshare Missions for small spacecraft on the Falcon 9 Launch Vehicle. This document applies to CubeSat dispensers and small spacecraft with an 8", 15", or 24" diameter standard mechanical interface, and in the case of small spacecraft, a single deployment from that interface. These spacecraft are referred to as "Payloads" throughout this document. Sub-components that comprise the Payload are referred to as "Payload Constituents".

As an optional service, which may incur an additional fee, SpaceX can provide alternative configuration information for Payloads that are not compatible with the 8", 15", or 24" diameter mechanical interface, for small spacecraft Payloads that require multiple deployments from the Launch Vehicle, or for Payloads that host multiple Payload Constituents that separate from an orbital transfer vehicle, or similar, after the Payload itself is deployed from the Launch Vehicle.

In an effort to reduce the orbital debris footprint of the Rideshare Program, Payloads must adhere to the FCC's ruling to dispose of spacecraft as soon as practicable but no later than 5 years after mission ends.

The timeline of a typical Rideshare contract is shown in Figure 1-2.

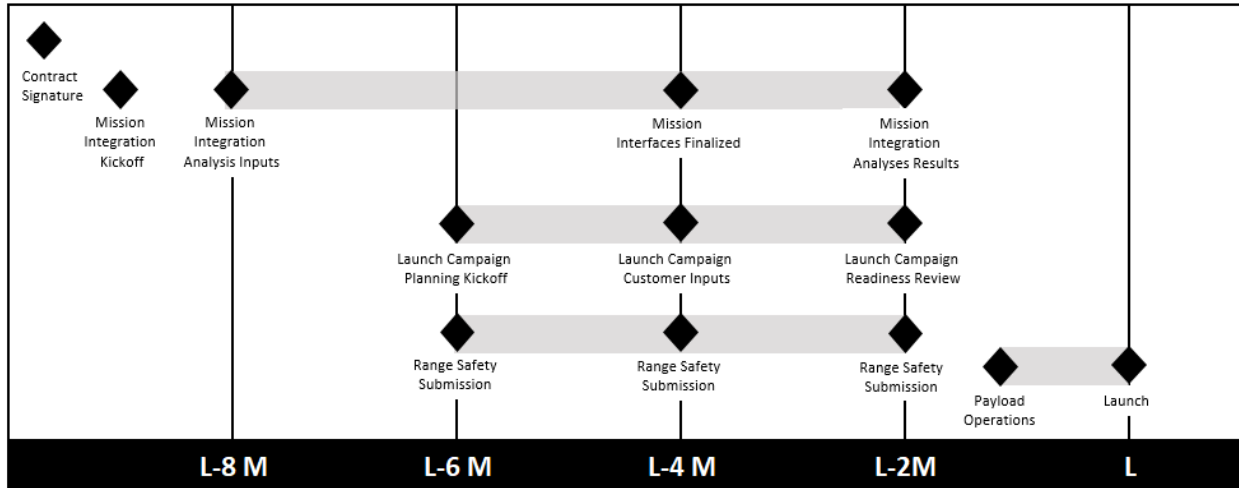


Figure 1-2: Typical Rideshare Program Schedule

SpaceX will provide kickoff materials shortly after the launch services contract is signed. To aid in communication, SpaceX will send document templates for Customer to complete. A descriptions of the documents associated with each milestone can be found in Appendix G.

To ensure a smooth Launch Campaign and a successful mission for all Rideshare Customers, SpaceX will maintain an Interface Control Document (ICD) for the Payload. Requirements in the ICD and this document are designed to ensure the safety of all Co-Payloads and the Launch Vehicle. SpaceX and Customer will periodically review and update the ICD throughout the mission integration process.

Approximately six months before Launch, Customer and SpaceX begin planning Range Safety and Launch Campaign operations. Before the Payload is delivered to the Launch Site, the ICD is signed and a review is held to confirm Launch Campaign readiness as well as the Payload specific schedule. The Payload is then shipped to the Launch Site, where it is integrated to the Launch Vehicle for Launch.

SpaceX will provide a best-estimate Payload separation state vector to the Customer shortly after Payload separation, as described in Appendix E. Customer is responsible for tracking and contacting the Payload after separation from the Launch Vehicle.

### 1.4 FALCON 9 PROGRAM

Please refer to the SpaceX Falcon User’s Guide, latest revision, available on [www.spacex.com/vehicles/falcon-9/](http://www.spacex.com/vehicles/falcon-9/) for detailed information regarding the Falcon program including Launch Vehicle safety and reliability.

### 1.5 PRICING

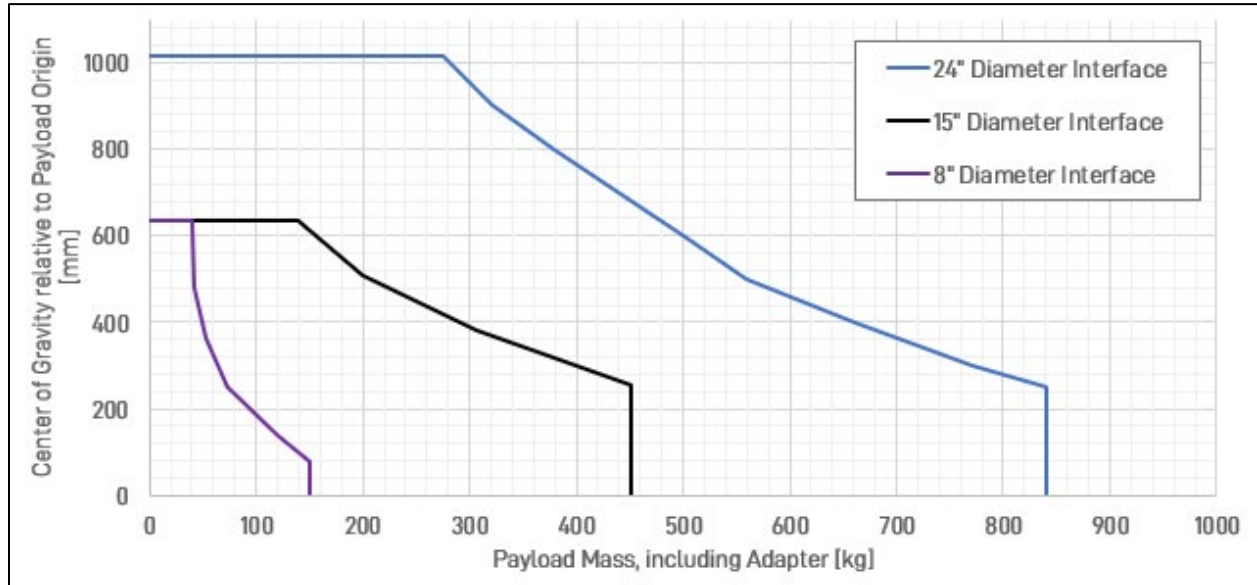
Pricing for rideshare Launch Services can be found at [www.spacex.com/rideshare](http://www.spacex.com/rideshare).



## 2 PERFORMANCE

### 2.1 MASS PROPERTIES

Payloads must comply with the mass and  $X_{PL}$  center of gravity limitations given in Figure 2-1.  $Y_{PL}$  and  $Z_{PL}$  center of gravity dimensions must fall within the mechanical interface diameter for the Payload. The Payload coordinate frame is defined in Section 4.2.3.



**Figure 2-1: Allowable Payload Mass and  $X_{PL}$  Center of Gravity**

The Launch Vehicle may be able to accommodate payloads with characteristics outside the limitations indicated in this section, on a case by case basis. Mass property capabilities may be further constrained by mission-unique Payload adapters, dispensers, or separation systems.

### 2.2 LAUNCH WINDOWS

The Launch Vehicle is capable of launching any day of the year, at any time of day, subject to environmental limitations and constraints as well as range availability and readiness within the SpaceX-determined Launch Period. Launch Window times and durations are developed specifically for each Mission. Customers may benefit from recycle operations (reference Section 7.5.5), maximizing launch opportunities within the Launch Window.





## 2.3 SEPARATION ATTITUDE AND ACCURACY

The Launch Vehicle offers 3-axis attitude control as standard practice. The Launch Vehicle will point the second stage and Payload to an attitude determined by SpaceX. More information about separation attitude and rate accuracy is available from SpaceX upon request.

## 2.4 SEPARATION RATES AND VELOCITY

All deployed Payloads must exit through the  $+X_{PL}$  surface of the allowable Payload volume. Customer must show by analysis that none of the deployed Payload Constituents contact other portions of the Payload before exiting the  $+X_{PL}$  surface of the allowable Payload volume. Examples of Payload volume exit criteria for Rideshare Plate and Starlink Adapter configurations are shown in Figure 2-2 and Figure 2-3 respectively.

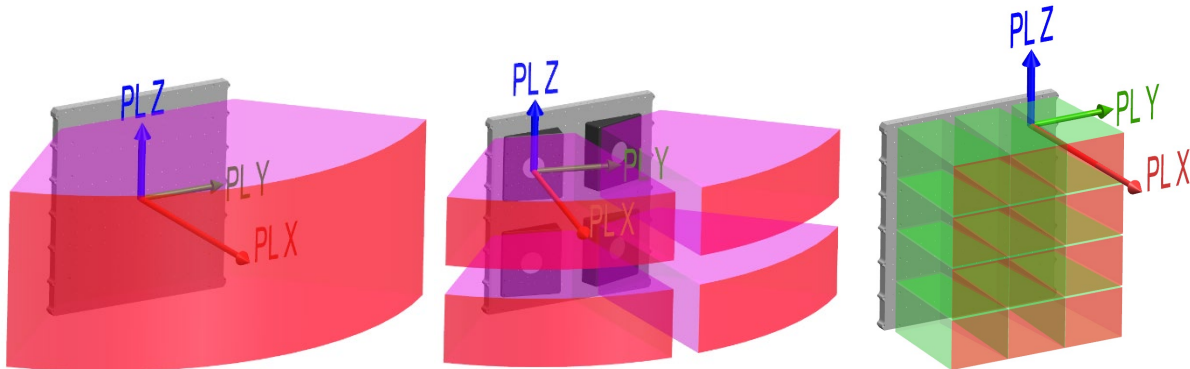


Figure 2-2: Payload  $+X_{PL}$  Surface Exit Requirement (red) for Rideshare Plate Configuration

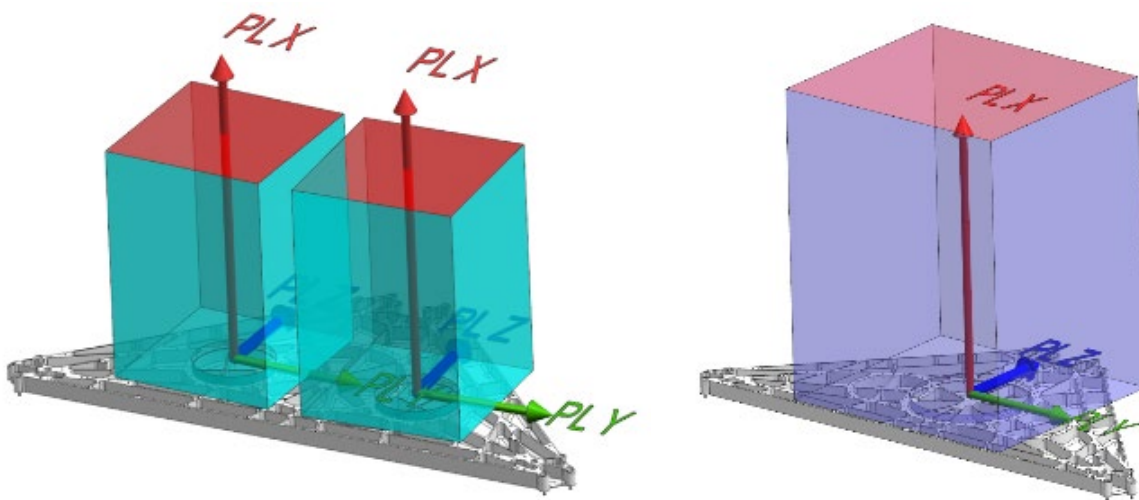


Figure 2-3: Payload  $+X_{PL}$  Surface Exit Requirement (red) for Starlink Adapter Configuration



Payloads must target a minimum separation velocity of 0.3 m/s and a maximum separation velocity of 1.0 m/s. Containerized deployments such as CubeSats may be deployed at a velocity greater than 1.0 m/s. For Payloads that contain more than one deployment, the separation velocities should be different between deployed Payload Constituents such that the fastest deployment is first.

The Launch Vehicle is subject to the rotational rates in Table 2-1 prior to Payload separation.

**Table 2-1: Launch Vehicle Rates Before Payload Separation**

Axis	Rate
Launch Vehicle Roll ( $W_x$ )	$\pm 2.0$ deg/s
Launch Vehicle Pitch ( $W_y$ )	$\pm 1.0$ deg/s
Launch Vehicle Yaw ( $W_z$ )	$\pm 1.0$ deg/s

## 2.5 PAYLOAD MANEUVERS AND DEPLOYMENTS

Payloads must adhere to the following keep outs:

- Delay attitude maneuvers until at least 120 seconds after Payload separation from the Launch Vehicle
- Delay mechanical appendage deployment (e.g. solar panel deployment) until at least 120 seconds after Payload separation from the Launch Vehicle
  - For any mechanical appendage deployment within first 24 hours, Customer must communicate to SpaceX a bounding hard body radius for the Payload.
- Delay secondary deployments (e.g. a deployed object deploying a sub-Payload) until at least seven days after Payload separation from the Launch Vehicle
- Delay propulsive maneuvers until at least seven days after Payload separation
- All secondary deployments must be performed while under active attitude control. Deployments in uncontrolled directions are not allowed.

The seven-day period allows adequate time for external cataloging of all Co-Payloads deployed from the Launch Vehicle and sufficient orbital spreading before additional release of Payload Constituents or orbital maneuvers. It is the Customer's responsibility to pre-coordinate orbital maneuvers or the secondary deployment of Payload Constituents with the 18th Space Control Squadron (SPCS), submit estimated trajectories for screening to the 18th SPCS, and demonstrate to SpaceX that coordination with the 18th SPCS has been completed. See Section 6.5.7 for information on Coordination with Space Situational Awareness Agencies.



### 3 ENVIRONMENTS

The Launch Vehicle has been designed to provide a benign Payload environment. The environments presented below reflect typical Mission maximum predicted environments (MPE) for Payloads. Mission-specific analyses will be performed by SpaceX as indicated in Section 6.6.9.

#### 3.1 TRANSPORTATION ENVIRONMENTS

Transportation environments at launch facilities will be enveloped by the flight environments in Section 3.3.

#### 3.2 CLEANROOM ENVIRONMENTS

The standard service temperature, humidity and cleanliness environments during various processing phases are provided in Table 3-1.

Conditioned air will only be disconnected for short durations (generally between 30 and 60 minutes) during pre-determined operations such as movements, lifts, and rollout to the pad. Payload environmental temperatures will be maintained above the dew point of the supply air at all times. The SpaceX supplied mechanical interface and fairing surface are cleaned to VC-HS.

**Table 3-1: Temperature and Cleanliness Environments**

Phase	Control System	Temp °C (°F)	Humidity	Cleanliness (class)
Payload Processing	PPF HVAC	21 ± 3 (70 ± 5)	CCSFS/KSC: 45% ± 15% VSFB: 50% ± 15%	100,000 (class 8) or better
Propellant Conditioning and Loading <sup>1</sup>	Facility HVAC		25% to 60%	
Transport to Hangar (CCSFS/KSC only)	Transport trailer unit			
Encapsulated in Hangar	Ducted supply from standalone HVAC unit or transport trailer unit (if required)		CCSFS/KSC: 45% ± 15% VSFB: 50% ± 15%	
Encapsulated Roll-Out to Pad	None (transport trailer unit if required)	No Control System	No Control System	
Encapsulated on Pad (Vertical or Horizontal)	Pad air conditioning	Bulk air temperature will remain between 10 and 32 (50 to 90), targeting 21 (70)	0% <sup>2</sup> to 65%	

Note:

1. Payload fueling is available as an optional service (see Appendix I) and is not part of the standard Rideshare services.
2. Supply air is switched to GN2 during the Launch Countdown sequence.



### 3.3 FLIGHT ENVIRONMENTS

This section describes the MPE the Payload will experience from liftoff through separation from the Launch Vehicle.

**IMPORTANT:** To ensure mission safety, Payloads must test all flight hardware as a fully integrated Payload (everything, including all Payload Constituents that comprise the Payload and attach to the SpaceX provided mechanical interface) consistent with the requirements defined in Sections 3.3 and 3.4. Integrated flight hardware testing provides workmanship screening as well as validation of design analyses for the entire Payload assembly. This testing is required to ensure safety of the primary Mission and of Co-Payloads.

#### 3.3.1 PAYLOAD NATURAL FREQUENCIES AND DAMPING

Payloads must have no elastic natural frequencies below 40 Hz and must have a damping values between  $Q=10$  and  $Q=50$  in order to ensure that the requirements defined in Section 3 are sufficient to cover the appropriate flight environments. Payloads with elastic natural frequencies below 40 Hz will not be permitted. An elastic natural frequency is defined in this document is any frequency response of the Payload with any modal participation, as computed by a fixed-base modal analysis.

#### 3.3.2 PAYLOAD DESIGN LOAD FACTORS

**Purpose:** To ensure structural integrity of the Payload to Launch Vehicle interface.

##### 3.3.2.1 DESIGN LOAD FACTORS FOR CUBESATS WITH CUBESAT DISPENSERS

Payload maximum predicted design load factors are shown in Table 3-2 for CubeSat deployers loaded with CubeSat Payloads. These load factors are defined as “combined loads,” which include all contributions from static loads, low frequency loads (<100 Hz), and high frequency loads (> 100 Hz). These load factors are applicable to CubeSat dispensers loaded with CubeSats that meet the requirements in Section 3.3.1 and have a combined mass of at least 20 kg.

**Table 3-2: CubeSat Dispenser (including CubeSats) Design Load Factors**

Axial ( $X_{PL}$ ) Load Factor (g)	Lateral (RSS $Y_{PL}$ , $Z_{PL}$ ) Load Factor (g)
10	17

##### 3.3.2.2 DESIGN LOAD FACTORS FOR MICROSATS AND SMALLSATS

Payload maximum predicted design load factors are shown in Figure 3-1 and Figure 3-2 as a function of Payload mass for the Rideshare Plates and Starlink Adapter configurations respectively. These load factors are defined as “combined loads,” which include all contributions from static loads, low frequency loads (<100 Hz), and high frequency loads (> 100 Hz). These load factors are applicable to payloads < 60 kg with a primary bending mode between 40-200 Hz and >60 kg with a primary bending mode between 40-100 Hz. Contact SpaceX if your primary mode is above these values.

The design load factors in the axial and lateral axes must be applied concurrently per the curves and the Customer must choose one of the four curves depending on Payload mass with no interpolation. For example, a 260 kg Payload mounted to a Rideshare Plate must design to a combined 5-g axial and 2-g lateral environment, as well as a combined 11-g lateral and 2.5-g axial environment.

Test verification for design load factors must, therefore, be based on peak line loads, which take into account both the axial force and bending moment contributions. If tests are performed in a single axis at a time, applied loads must be shown to sufficiently achieve the maximum line load at the Launch Vehicle interface as defined by the corners of the design load factor box.

In the case of a 260 kg Payload with an axial center-of-gravity 300 mm along  $X_{PL}$  on a 24” diameter interface, testing would need to achieve an equivalent line load of 32.1 N/mm, as defined by the concurrent 11-g lateral and 2.5-g axial design requirement. In turn, this could be achieved by applying 12.3-g in the lateral direction via a single-axis test.



As the “port lateral” loads are an RSS of  $Y_{PL}$  and  $Z_{PL}$  loads in flight they could be applied in any direction onto the spacecraft in the  $Y_{PL}$  -  $Z_{PL}$  plane. If a Payload or separation system is more sensitive to one orientation of load in the  $Y_{PL}$  -  $Z_{PL}$  plane that orientation must be tested or engineering rationale must be provided to SpaceX. For example, a 4-point mount separation system will see higher loads when the lateral load is aligned with one of the mounts rather than 2 of the mounts, so testing of the separation system and Payload should reflect this worst case scenario.

These loads represent the overall net CG response of a Payload and *should not* be utilized for internal component, appendage, or Payload Constituent loads.

**Verification:** Testing is **REQUIRED** to the static load test levels and durations defined in Table 3-15 in accordance with the MPE defined in this section. Static load test requirements can be achieved through sine burst testing, sine sweep testing, random vibration, or static load tests. If using sine sweep or random vibration testing, start with the specifications listed below and adjust the levels and/or notch the levels until the appropriate interface forces are achieved.

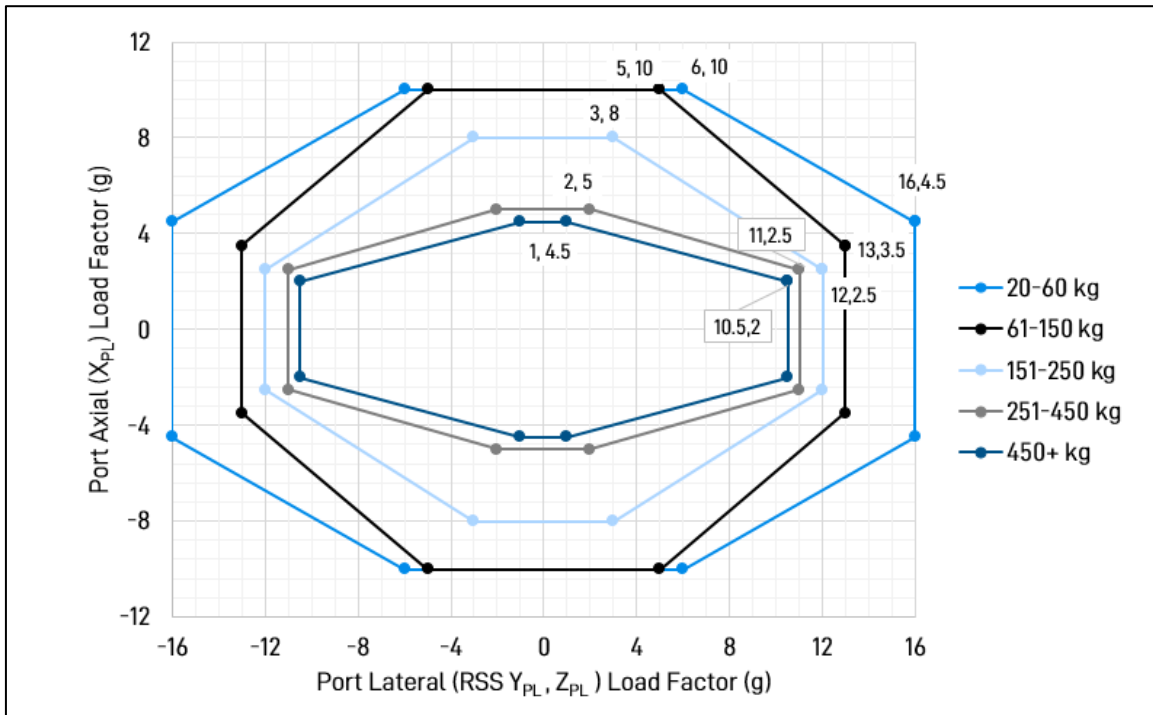


Figure 3-1: Rideshare Plate Payload Design Load Factors

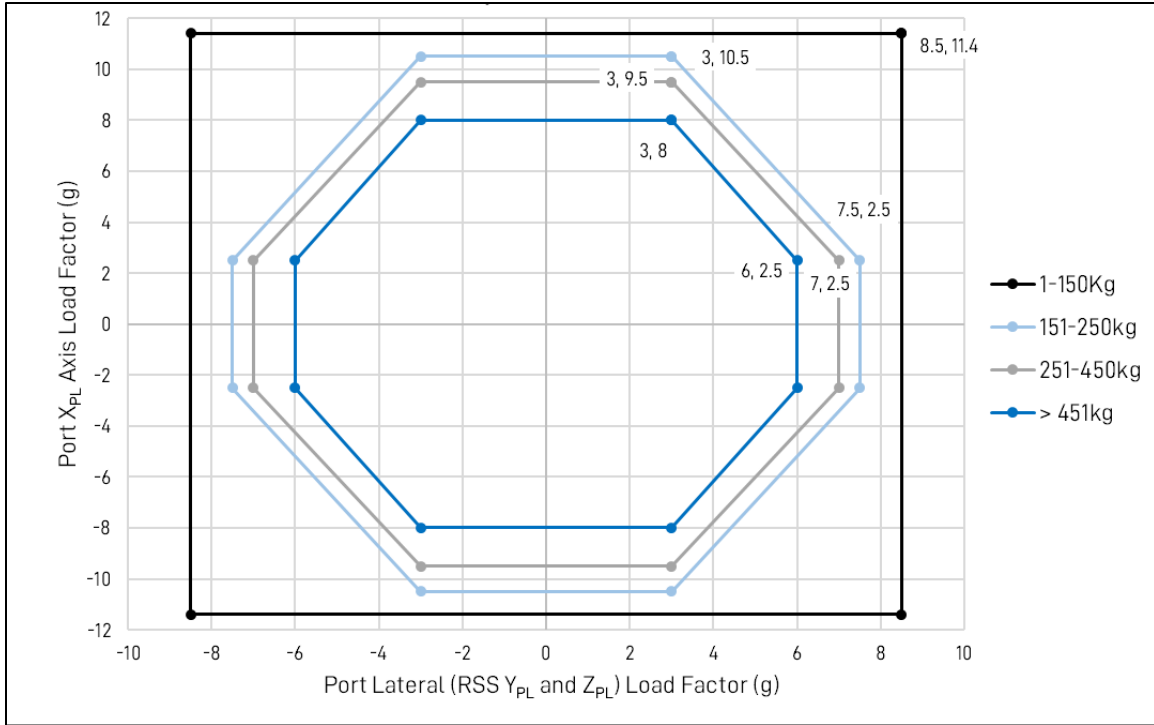


Figure 3-2: Starlink Adapter Payload Design Load Factors

3.3.3 SINE VIBRATION

**Purpose:** To ensure Payloads are compatible with loads imparted on primary and secondary structures with modes < 100 Hz.

The maximum predicted sine vibration environment is defined in Table 3-3. This environment is defined for Payloads with  $Q \geq 10$  in Rideshare Plate and Starlink Adapter configurations, and may be notched at primary mode(s) to stay within the design load factors defined in Section 3.3.2.

**Verification:** Testing is ADVISED to the sine vibration test levels and durations defined in Table 3-15 in accordance with the MPE defined in this section.

Table 3-3: Maximum Predicted Sinusoidal Vibration Environment

Frequency (Hz)	Rideshare Plate Sinusoidal Vibration MPE (g)		Starlink Adapter Sinusoidal Vibration MPE (g)	
	Axial $X_{PL}$	Lateral $Y_{PL}, Z_{PL}$	Axial $X_{PL}$	Lateral $Y_{PL}, Z_{PL}$
	5	1.4	1.5	3.0
45	1.4	1.5	3.0	1.5
50	1.4	1.5	3.0	2.0
100	1.4	1.5	3.0	2.0

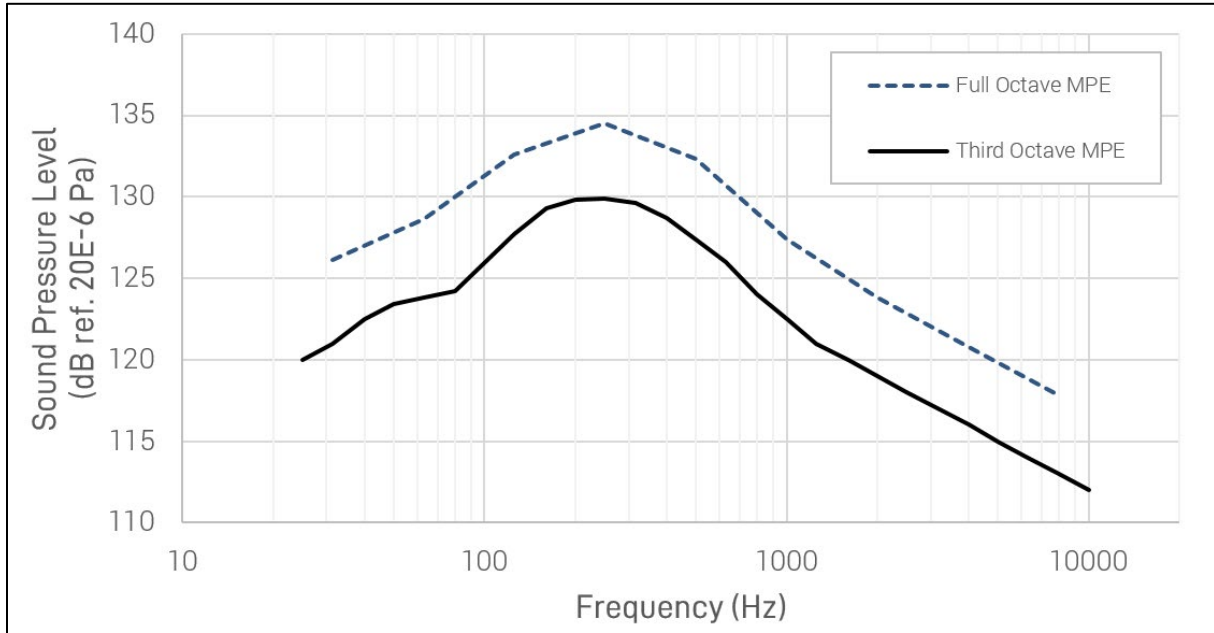
3.3.4 ACOUSTIC

**Purpose:** To ensure Payloads are compatible with acoustic environments inside the Launch Vehicle fairing. Note that most Rideshare sized Payloads are driven by structure-borne random vibration (Section 3.3.6) and not by direct acoustic impingement.

The maximum predicted acoustic environment, defined as the spatial average and derived at a P95/50 level, is shown below in Figure 3-3. Table 3-4 and Table 3-5 defines the environment in third octave and full octave respectively. A Mission-specific analysis will not be provided by SpaceX.



**Verification:** Testing is ADVISED to the acoustic test levels and durations defined in Table 3-15 in accordance with the MPE defined in this section.



**Figure 3-3: Maximum Predicted Acoustic Environment**

**Table 3-4: Third Octave Acoustic MPE**

Frequency (Hz)	Acoustic MPE
25	120.0
31.5	121.0
40	122.5
50	123.4
63	123.8
80	124.2
100	125.9
125	127.7
160	129.3
200	129.8
250	129.9
315	129.6
400	128.7
500	127.4
630	126.0
800	124.0
1000	122.5
1250	121.0
1600	120.0
2000	119.0
2500	118.0
3150	117.0
4000	116.0
5000	115.0
6300	114.0
8000	113.0
10000	112.0
<b>OASPL (dB)</b>	<b>139.3</b>

**Table 3-5: Full Octave Acoustic MPE**

Frequency (Hz)	Acoustic MPE
31.5	126.1
63	128.6
125	132.6
250	134.5
500	132.3
1000	127.4
2000	123.8
4000	120.8
8000	117.8
<b>OASPL (dB)</b>	<b>139.3</b>



### 3.3.5 SHOCK

**Purpose:** To ensure Payloads are compatible with shock environments experienced during flight.

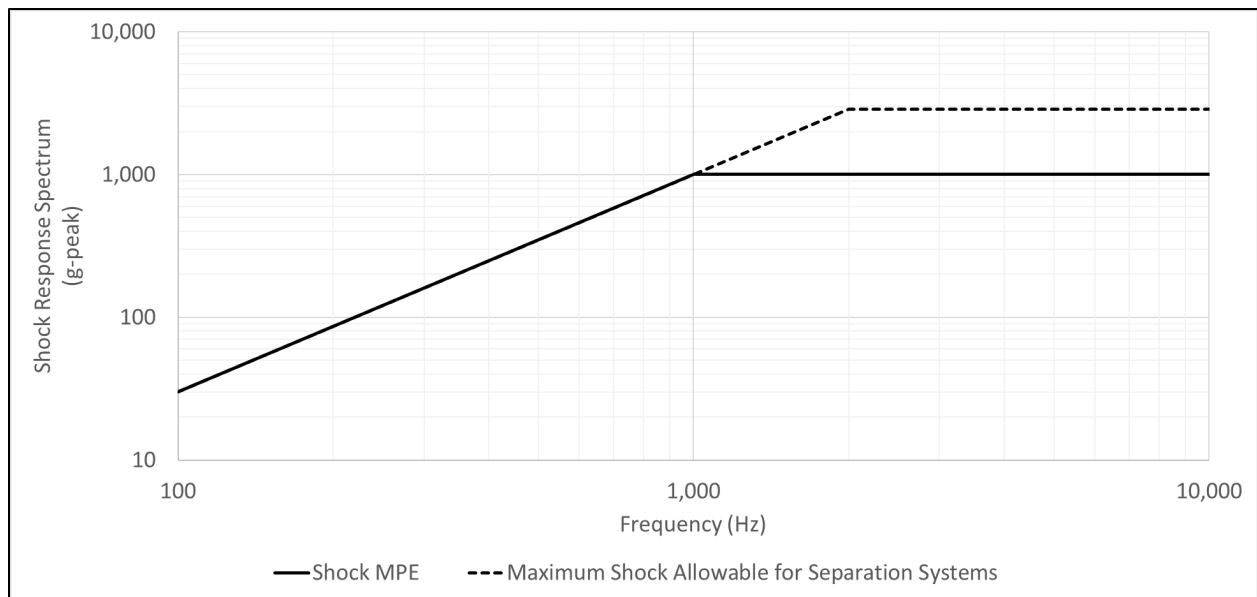
The shock response spectrum MPE, for Q=10, at the Payload mechanical interface for fairing deployment and Co-Payload separation(s), as well as the maximum allowable shock for a single separation system are defined in Table 3-6 and Figure 3-4. These levels are defined assuming a minimum of 3 bolted joints between Co-Payloads. Customers flying mission-unique configurations are encouraged to independently evaluate the shock levels produced by their Payload's separation system.

Customer is responsible for verifying compliance to both this requirement and the shock levels for the Payload separation system. To ensure Mission safety for Co-Payloads, separation systems provided by the Customer must be approved by SpaceX (reference Section 3.4.1.3). Additional constraints may be imposed if the separation system exceeds shock levels listed in Table 3-6. A Mission-specific analysis will not be provided by SpaceX.

**Verification:** Testing is ADVISED to the shock test levels and durations defined in Table 3-15 in accordance with the MPE defined in this section.

**Table 3-6: Payload Mechanical Interface Shock**

Frequency (Hz)	MPE Induced by Launch Vehicle and Co-Payload(s) SRS (g)	Maximum Allowable Induced by Payload Separation System SRS (g)
100	30	30
1000	1000	--
1950	--	2850
10000	1000	2850



**Figure 3-4: Payload Mechanical Interface Shock**

### 3.3.6 RANDOM VIBRATION

**Purpose:** To ensure structural integrity of the Payload during flight dynamic events. Exposure to the random vibration environment ensures that primary structures, secondary structures, Payload Constituents, and smaller components are exposed to flight loads plus margin. This exposure is required for Mission safety and Co-Payload safety.

The random vibration MPE for the Payload is defined in Figure 3-5 and Table 3-7. In verifying compliance to this requirement, acceleration response-limited or interface force-limited testing may be acceptable and will be reviewed by



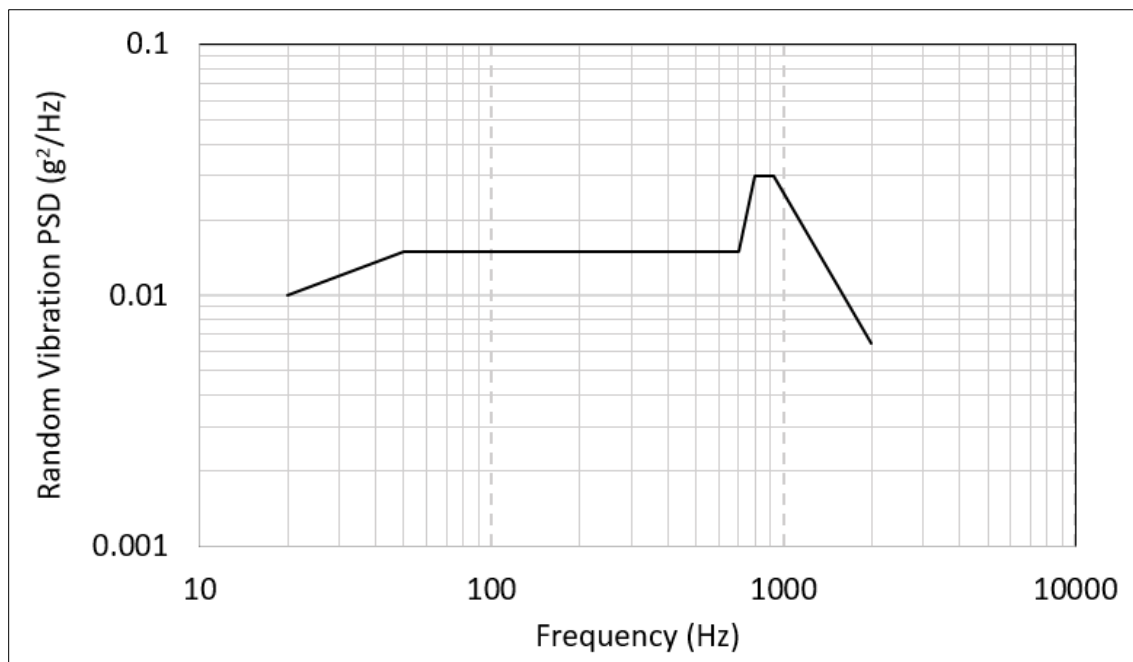


SpaceX along with final report documentation. In general, force-limited testing is allowed to a  $C^2$  value of five (5) or higher and must be in accordance with NASA-HDBK-7004C with a maximum notch depth of -10 dB. Notching is only permitted to prevent the Payload from exceeding the static load levels defined in Table 3-15. Notching to protect secondary structure or constituent responses is not permitted because that would result in an under-test as related to flight environments. A Mission-specific analysis will not be provided by SpaceX.

**Verification:** Testing is **REQUIRED** to the random vibration test levels and durations defined in Table 3-15 in accordance with the MPE defined in this section. This random vibration test can also be used to meet the design loads factors requirement defined in Section 3.3.2.

**Table 3-7: Random Vibration MPE**

Frequency (Hz)	Random Vibration MPE (P95/50), All Axes
20	0.01
50	0.015
700	0.015
800	0.03
925	0.03
2000	0.00644
<b>GRMS</b>	<b>5.57</b>



**Figure 3-5: Random Vibration MPE**

### 3.3.7 ELECTROMAGNETIC

**Purpose:** To ensure that Launch Vehicle and launch site radiated emissions do not compromise electrical integrity of the Payload, and to ensure that Payload emissions do not compromise safety of the Launch Vehicle or of Co- Payloads during the mission.

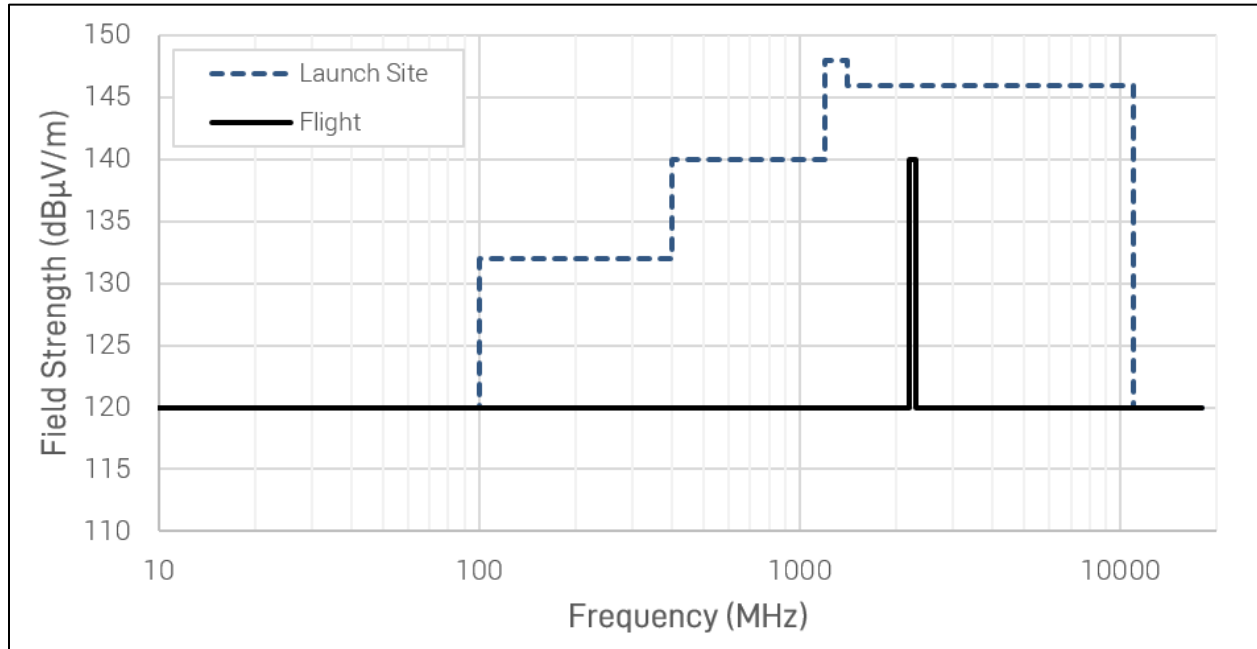
The Payload must show compliance with the electromagnetic environments in the following sections. Payload electromagnetic specifications will be captured in the Payload-specific ICD.



**Verification:** Testing or verification by analysis is **REQUIRED** to the electromagnetic compatibility test levels and durations defined in Table 3-15 in accordance with the environments defined in this section.

### 3.3.7.1 IN-FLIGHT AND PRE-FLIGHT ENVIRONMENTAL EMISSIONS

Customer must ensure that Payload materials or components sensitive to RF environments are compatible with the worst-case radiated environment shown in Figure 3-6. Launch Vehicle, including Co-Payloads, and Launch Site radiated emissions, are shown in Table 3-8 and Table 3-9 respectively. EMI margin is not included.



**Figure 3-6. In-Flight & Environmental Radiated Emissions / Payload Radiated Susceptibility Limit**

**Table 3-8: Launch Vehicle Radiated Emissions**

Frequency Range (MHz)	E-Field Limit (dBμV/m)
1.00 – 2200.0	120
2200.0 – 2300.0	140
2300.0 – 18000.0	120

**Table 3-9: Launch Site Radiated Emissions**

Frequency Range (MHz)	E-Field Limit (dBμV/m)
1.00 – 100	120
100 – 400	132
400 – 1200	140
1200 – 1400	148
1400 – 11000	146
11000 – 18000	120

These limits envelope the expected emissions from the Launch Vehicle, Co-Payloads, and Launch Site radar transmitters. Customer should assume 26 dB of shielding from Launch Site sources when testing and integrating the Payload in either the PPF or the Hangar Annex.



### 3.3.7.2 MAXIMUM PAYLOAD EMISSIONS

The emission envelope for Dedicated Rideshare Missions and Secondary Rideshare Missions, including 6 dB of EMI safety margin by test, or 12 dB of EMI safety margin by analysis, is shown in Table 3-10.

**Table 3-10: Maximum Payload Emissions**

Frequency Range (MHz)	Dedicated Rideshare		Secondary Rideshare	
	by Test (dB $\mu$ V/m)	by Analysis (dB $\mu$ V/m)	by Test (dB $\mu$ V/m)	by Analysis (dB $\mu$ V/m)
30.0 – 1555.42	90	84	48	42
1555.42 – 1595.42	48	42	48	42
30.0 – 18000.0	90	84	48	42

Standard launch services do not permit use of Payload transmitters while integrated to the Launch Vehicle hardware. Payload transmitters may be enabled after the time interpolated using the information found in Table 3-11 for Dedicated Rideshare Missions and Table 3-12 for Secondary Rideshare Missions.

Additionally, any transmitter centered in the (2227.5 - 2237.5 MHz), (2267.5 - 2277.5 MHz), and (2206 - 2216 MHz) bands must wait to enable these transmitters until “End of Mission,” as defined by the Mission-specific second stage re-entry time (usually a maximum of 1 hour, or 3600 seconds, after the first deploy).

**Table 3-11: Dedicated Rideshare Mission Transmitter Delay Time (seconds)**

EIRP (Watts)		0.00001	0.0001	0.001	0.01	0.1	1	10	19.95	100	1000
EIRP (dBm)		-20	-10	0	10	20	30	40	43	50	60
Separation Velocity (m/s)	0.1	0.260	0.822	2.599	8.216	26.0	82.2	260	367	822	2599
	0.2	0.130	0.411	1.30	4.108	13.0	41.1	130	184	411	1300
	0.5	0.052	0.165	0.52	1.644	5.197	16.5	52.0	73.4	165	520
	1.0	0.026	0.083	0.26	0.822	2.599	8.216	26.0	36.7	82.2	260
	2.0	0.013	0.042	0.13	0.411	1.30	4.108	13.0	18.4	41.1	130
	5.0	0.006	0.017	0.052	0.165	0.52	1.644	5.197	7.34	16.5	52.0

**Table 3-12: Secondary Rideshare Mission Transmitter Delay Time (seconds)**

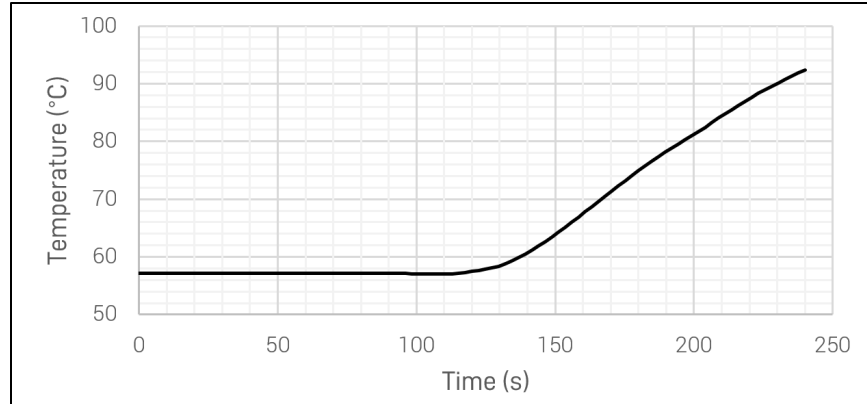
EIRP (Watts)		0.00001	0.0001	0.001	0.01	0.1	1	10	19.95	100	1000
EIRP (dBm)		-20	-10	0	10	20	30	40	43	50	60
Separation Velocity (m/s)	0.1	7.746	24.5	77.5	245	775	2450	7746	10942	24495	77460
	0.2	3.873	12.3	38.8	123	388	1225	3873	5471	12248	38730
	0.5	1.550	4.899	15.5	49.0	155	490	1550	2189	4899	15492
	1.0	0.775	2.45	7.746	24.5	77.5	245	775	1095	2450	7746
	2.0	0.388	1.225	3.873	12.3	38.8	123	388	548	1225	3873
	5.0	0.155	0.49	1.55	4.899	15.5	49.0	155	219	490	1550

### 3.3.8 FAIRING INTERNAL PRESSURE

Fairing internal pressure will decay at a rate no larger than 0.40 psi/sec (2.8 kPa/sec) from liftoff through immediately prior to fairing separation, except for brief periods during flight, where the fairing internal pressure will decay at a rate no larger than 0.65 psi/sec (4.5 kPa/sec), for no more than 5 seconds. A Mission-specific analysis will not be provided by SpaceX.

### 3.3.9 PAYLOAD TEMPERATURE EXPOSURE DURING FLIGHT

The Launch Vehicle fairing is designed such that the temperature seen by the Rideshare Payload never exceeds the temperature profile shown in Figure 3-7. The emissivity of the fairing is approximately 0.9.



**Figure 3-7. Maximum Fairing Spot Temperature Seen by Rideshare Payload**

### 3.3.10 FREE MOLECULAR HEATING

The maximum free molecular aero-thermal heating rate experienced by the Payload is less than  $3,500 \text{ W/m}^2$  at fairing separation. Free molecular aero-thermal heating declines significantly and becomes negligible over the next couple of minutes.

### 3.3.11 PAYLOAD CONDUCTIVE BOUNDARY TEMPERATURES

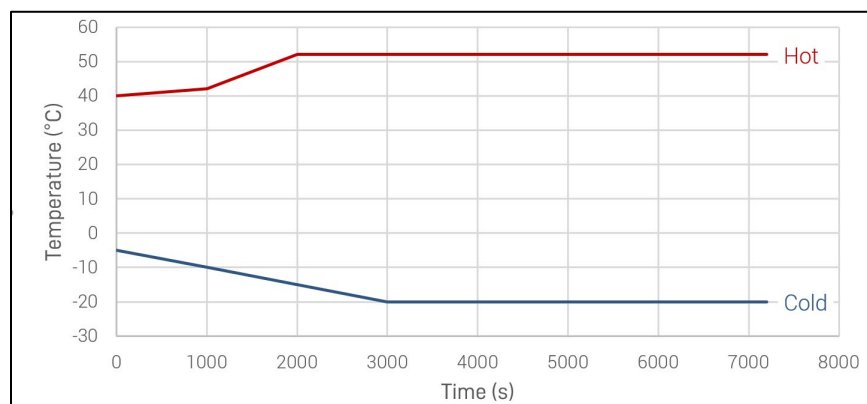
Bounding hot and cold boundary temperatures and conductance values at the interface of the Payload and the SpaceX-provided Mechanical Interface, described in Section 4.2.4, are shown in Table 3-13 and Figure 3-8.

Customer may use these boundary conditions to run a Payload-specific thermal analysis. Note that these boundary conditions are only relevant after Liftoff at Time = 0 as they contain analysis uncertainty that is not appropriate on the ground. The convective environment in Table 3-1 fully defines the pre-launch environment. A Mission-specific analysis will not be provided by SpaceX.

**Verification:** Testing is ADVISED to the combined thermal vacuum and thermal cycle test levels and durations defined in Table 3-15 in accordance with the environments defined in this section.

**Table 3-13: Bounding Conductive Boundary Temperature and Conductance**

Time (s)	Hot Temperature (°C)	Cold Temperature (°C)	Min Conductance (W/°C)	Max Conductance (W/°C)
0	40	-5	0	7.7
1000	42	-10	0	7.7
2000	52	-15	0	7.7
3000	52	-20	0	7.7
7200	52	-20	0	7.7



**Figure 3-8: Bounding Conductive Boundary Temperature**



### 3.3.12 CONTAMINATION

Payload contamination must meet the requirements in Table 3-14.

**Verification:** Customer is responsible for verifying compliance to this requirement in the form of a Payload contamination report.

**Table 3-14: Payload Contamination Requirements**

Name	Description
Visual Cleanliness	Payloads must be cleaned to VC-HS standards per NASA-SN-C-005D prior to integration onto Launch Vehicle hardware.
Non-Metallic Materials	Each individual non-metallic material used in the construction of the Payload that will be exposed to vacuum must not exceed a total mass loss of 1.0% and the volatile condensable matter must be less than 0.1% when tested per ASTM E595. This would include avoiding use of markers, pens, and paint pens to mark Payload hardware. A complete vacuum-exposed non-metallic materials list including quantities (surface area or mass) will be delivered to SpaceX for review. Any exceedances will be evaluated and approved on a case-by-case basis.
Metallic Materials	The selection of metallic materials by the Customer will include consideration of corrosion, wear products, shedding, and flaking in order to reduce particulate contamination. Dissimilar metals in contact will be avoided unless adequately protected against galvanic corrosion.
Payload Particulate Generation	The Payload will not create particulate during the vibroacoustic ascent environment. Actuation of any Payload mechanisms nearby any Co-Payload(s) or Launch Vehicle Hardware must not create particulate.
Payload Deployment	The Payload deployment system will not include the use of uncontained pyrotechnics (e.g. Frangible nuts).
Payload Propulsion	Payload propulsion systems will not be operated in close proximity (within 1 km) of Co-Payload(s).
Prohibited Materials	The following materials are not to be used on Payload hardware: <ul style="list-style-type: none"><li>• cadmium parts</li><li>• cadmium-plated parts</li><li>• zinc plating</li><li>• mercury, compounds containing mercury</li><li>• pure tin or tin electroplate (except when alloyed with lead, antimony, or bismuth)</li></ul>
Silicone Sensitivity	All silicone rubber or RTV silicones with probability of transfer to Co-Payload(s) or Launch Vehicle hardware will require SpaceX approval, coordination, and notification prior to use.



### 3.4 ENVIRONMENTAL VERIFICATION TESTING

Customer must verify the compatibility of the Payload with the maximum predicted environments defined in Section 3.3. SpaceX will review the Customer's chosen verification approach as well as test results during Mission integration to ensure Mission safety.

#### 3.4.1 VERIFICATION APPROACH

SpaceX allows two approaches to environmental verification testing: Fleet Qualification and Flight Unit Protoqualification.

- Fleet Qualification: A qualification unit is subjected to testing at qualification levels and every flight unit is tested to acceptance test levels. The acceptance tests must be performed at the fully integrated Payload assembly level, even if the Payload consists of multiple smaller Payload Constituents. Qualification can be performed at the Payload Constituent level. With this approach the qualification test validates the structural design while the acceptance test(s) validate workmanship.
- Flight Unit Protoqualification: Each Payload flight unit is subjected to protoqualification test levels. Testing must be performed at the fully integrated Payload assembly level, even if the Payload consists of multiple smaller Payload Constituents. With this approach the protoqualification test validates both structural design and workmanship.

Every Payload flying on a SpaceX Rideshare Mission must undergo either fleet qualification or flight unit protoqualification environmental verification testing. Payloads using a fleet qualification approach must submit evidence that the qualification unit is sufficiently similar to the flight unit. The environments verification approach in this section is designed to ensure the safety of Co-Payloads and the Launch Vehicle. Tests that are "Advised" are designed to ensure on-orbit health and functionality of the Payload but are not required in order to fly on a SpaceX Rideshare Mission. Tests that are "Required" must be completed by the Customer to ensure mission safety through Payload separation.

#### 3.4.1.1 TEST-LIKE-YOU-FLY EXCEPTIONS

For acceptance and protoqualification tests performed on the flight Payload units, test-like-you-fly exceptions must be approved by SpaceX. Test-like-you-fly exceptions include all changes from the flight configuration to the test configuration. Rationale for the deviation must be provided to SpaceX. Common examples include:

- Not testing propulsion systems at flight pressure during the test
- Not filling propulsion tanks with reactive propellants during the test
- Not including separation system during the test (see Section 3.4.1.3)
- Mass models or engineering models used in place of flight hardware

#### 3.4.1.2 POST-INTEGRATED TEST MODIFICATIONS

Limited disassembly of the Payload for functional checkouts after the integrated test is allowed, as long as the following criteria are met:

- Fastened joints that meet the criteria in Section 4.1.2 are eligible for disassembly after test. Workmanship sensitive joints (adhesive, epoxy, brazed, welded, etc.) require a retest if they are modified after testing. Re-assembly after test must follow the fastener installation requirements in Section 4.1.2.
- Deployment mechanisms that are re-assembled after testing must demonstrate similar workmanship insensitivity, redundant workmanship controls, post-reassembly proof testing, or retest of random vibration acceptance levels for 30 seconds in the most stressing single axis.



### **3.4.1.3 PAYLOAD SEPARATION SYSTEM QUALIFICATION**

Each individual separation system must undergo qualification testing. It is required that each Payload separation system be included in the fully integrated Payload assembly acceptance or protoqualification test campaign.

SpaceX reserves the right to reject a Customer request to exclude the Payload separation system during fully integrated Payload testing. Exceptions, if approved, can only be granted if the separation system has been onboarded to the SpaceX catalogue. New separation systems can be onboarded to the SpaceX catalogue and may incur additional costs. For a list of separation systems already included in the catalogue or for information on the onboarding process, contact SpaceX.

### **3.4.2 DOCUMENTATION REQUIREMENTS**

Customer must deliver to SpaceX an environmental test approach summary, including test-like-you-fly exceptions, for review by SpaceX prior to Payload testing as defined in the Payload contract's Statement of Work (SOW).

A summary of the verification test results for the completed testing is due before the Launch Campaign Readiness Review as defined in the SOW. The summary report must include all test-like-you-fly exceptions for approval by SpaceX, including details on test versus flight boundary conditions, and any hardware not included in the test set up that will be in the flight configuration. If Customer chooses not to complete any "Advised" tests an acknowledgment of the inherent risks to the Payload incurred by not completing the "Advised" testing must be included within the summary report.



### 3.4.3 PAYLOAD UNIT TEST LEVELS

Payload unit testing must conform to the parameters shown in Table 3-15. Fully containerized CubeSat levels are provided in Table 3-16.

**Table 3-15: Payload Unit Test Levels and Durations**

Test	Required/Advised	Fleet Qualification		Flight Unit
		Qualification	Acceptance Must be performed on fully integrated Payload assembly	Protoqualification Must be performed on fully integrated Payload assembly
Static Load <sup>1</sup>	REQUIRED	1.25 times the limit load	1.1 times the limit load	1.25 times the limit load
Sine Vibration	Advised	1.25 times limit levels, two octave/minute sweep rate in each of 3 axes	1.0 times limit levels, four octave/minute sweep rate in each of 3 axes	1.25 times limit levels, two octave/minute sweep rate in each of 3 axes
Acoustic	Advised	6 dB above acceptance for 2 minutes	MPE spectrum for 1 minute	3 dB above acceptance for 1 minute
Shock	Advised	6 dB above MPE, 3 times in each of 3 orthogonal axes	Not Required	3 dB above MPE, 2 times in each of 3 orthogonal axes
Random Vibration	REQUIRED	6 dB above acceptance for 2 minutes in each of 3 axes	MPE spectrum for 1 minute in each of 3 axes	3 dB above acceptance for 1 minutes in each of 3 axes
Electromagnetic Compatibility <sup>2,3</sup>	REQUIRED	6 dB EMISM by Test or 12 dB EMISM by Analysis	Not Required	6 dB EMISM by Test or 12 dB EMISM by Analysis
Combined Thermal Vacuum and Thermal Cycle <sup>4</sup>	Advised	±10 °C beyond acceptance for 27 cycles total	Envelope of MPT and minimum range (-24 to 61 °C) for 14 cycles total	±5 °C beyond acceptance for 20 cycles total
Pressure System <sup>5,6</sup>	REQUIRED	Pressures as specified in Table 6.3.12-2 of SMC-S-016 following acceptance proof pressure test, duration sufficient to collect data. Minimum 2.0 times MEOP.	1.5 times ground MEOP for pressure vessels and pressure components. Other metallic pressurized hardware items per References 4 and 5 from SMC-S-016	See Note 5
System-Level Pressure Leak Test <sup>7</sup>	REQUIRED	Not Required	Full Pressure System MEOP Leak Test per Section 4.1.5.1	Full Pressure System MEOP Leak Test per Section 4.1.5.1
Pressure Vessel Leak Test <sup>7</sup>	REQUIRED	Not Required	Pressure Vessel Level MEOP Leak Test per Section 4.1.4.2	Pressure Vessel Level MEOP Leak Test per Section 4.1.4.2

Notes:

1. Static load testing can be achieved through a sine-burst test. In some instances, either random vibration or sine vibration testing at the levels described in this table may surpass the static load factors. Please contact SpaceX for more information.
2. Verification by test may be performed in-house per MIL-STD-461 with supporting test documentation or obtained from an IEC-17025 accredited (or equivalent) test facility. Verification by analysis must provide (1) a mechanical battery isolation inhibit strategy verified in vibrational testing or (2) electromagnetic circuit and wiring emissions analysis. For Payloads with GPS receivers, verification by analysis may be achieved through demonstration of self-compatibility with on-board GPS navigation systems.
3. EMISM (6 dB by test, 12 dB by analysis) is already included in Table 3-10.
4. Thermal cycles can be accrued as a combination of thermal cycling in air and thermal vacuum. It is recommended to include at least four cycles of thermal vacuum unless strong rationale exists that the Payload is not sensitive to vacuum.
5. Pressure systems cannot be protoqualified at the Payload level. Pressure systems must therefore be qualified via the fleet qualification approach at the component level. Supplier qualification testing is acceptable in place of fleet level qualification testing if approved by SpaceX. Reference Section 4.1.4 and Section 4.1.5 for additional information.
6. For all Non US Department of Transportation (US DOT) rated pressure vessels, please contact SpaceX for detailed qualification and testing requirements (reference Section 4.1.4).
7. Pressure Systems that do not meet material compatibility requirements specified in Section 4.1.5.2 must contact SpaceX for specific leak testing requirements





### 3.4.4 FULLY CONTAINERIZED CUBESAT UNIT TEST LEVELS

Fully containerized CubeSats may be tested at the Payload Constituent level using the unit test levels and durations defined below in Table 3-16. If these CubeSats are not included in the fully integrated Payload assembly level test (defined in Section 3.4.3) then mass models must be used in their place to represent the omitted CubeSats.

CubeSats are considered fully containerized if there are no holes in the dispenser/deployer larger than 0.250" [6.35 mm] in diameter, and holes make up less than 10% of the total surface area of the dispenser. CubeSats utilizing deployment devices that are not fully containerized do not fall within this specification, nor does this section apply to the CubeSat dispenser/deployer itself. Both the CubeSat dispenser/deployer as well as CubeSats that are not fully-containerized as defined above must be tested at the Payload levels defined in Table 3-15.

**Table 3-16: Containerized CubeSat Unit Test Levels and Durations**

Test	Required/Advised	Fleet Qualification		Single Unit
		Qualification	Acceptance	Protoqualification
Static Load		Not Required		
Sine Vibration		Not Required		
Acoustic		Not Required		
Shock	Advised	6 dB above MPE, 3 times in each of 3 orthogonal axes	Not Required	3 dB above MPE, 2 times in each of 3 orthogonal axes
Random Vibration <sup>1</sup>	REQUIRED	3 dB above acceptance for 2 minutes in each of 3 axes	MPE spectrum for 1 minute in each of 3 axes	MPE spectrum for 1 minute in each of 3 axes
Electromagnetic Compatibility <sup>2,3</sup>	REQUIRED	6 dB EMISM by Test or 12 dB EMISM by Analysis	Not Required	6 dB EMISM by Test or 12 dB EMISM by Analysis
Combined Thermal Vacuum and Thermal Cycle <sup>4</sup>	Advised	±10 °C beyond acceptance for 27 cycles total	Envelope of MPT and minimum range (–24 to 61 °C) for 14 cycles total	±5 °C beyond acceptance for 20 cycles total
Pressure Systems <sup>5,6</sup>	REQUIRED	Pressures as specified in Table 6.3.12-2 of SMC-S-016 following acceptance proof pressure test, duration sufficient to collect data. Minimum 2.0 times MEOP	1.5 times ground MEOP for pressure vessels and pressure components. Other metallic pressurized hardware items per References 4 and 5 from SMC-S-016	See Note 5
System-Level Pressure Leak Test <sup>7</sup>	REQUIRED	Not Required	Full Pressure System MEOP Leak Test per Section 4.1.5.1	Full Pressure System MEOP Leak Test per Section 4.1.5.1
Pressure Vessel Leak Test <sup>7</sup>	REQUIRED	Not Required	Pressure Vessel Level MEOP Leak Test per Section 4.1.4.2	Pressure Vessel Level MEOP Leak Test per Section 4.1.4.2

Notes:

1. SpaceX requires random vibration testing on CubeSats to no less than the MPE levels defined in Section 3.3.6, however strongly advises that the MPE is derived from fully integrated Payload assembly level testing. Failure to use derived random vibration levels should be understood by Customer to be an under-test to the expected flight environments.
2. Verification by test may be performed in-house per MIL-STD-461 with supporting test documentation or obtained from an IEC-17025 accredited (or equivalent) test facility. Verification by analysis must provide (1) a mechanical battery isolation inhibit strategy verified in vibrational testing or (2) electromagnetic circuit and wiring emissions analysis. For Payloads with GPS receivers, verification by analysis may be achieved through demonstration of self-compatibility with on-board GPS navigation systems.
3. EMISM (6 dB by test, 12 dB by analysis) is already included in Table 3-10.
4. Thermal cycles can be accrued as a combination of thermal cycling in air and thermal vacuum. It is recommended to include at least four cycles of thermal vacuum unless strong rationale exists that the Payload is not sensitive to vacuum.
5. Pressure systems cannot be protoqualified at the Payload level. Pressure systems must therefore be qualified via the fleet qualification approach at the component level. Supplier qualification testing is acceptable in place of fleet level qualification testing if approved by SpaceX. Reference Section 4.1.4 and Section 4.1.5 for additional information.
6. For all Non US Department of Transportation (US DOT) rated pressure vessels, please contact SpaceX for detailed qualification and testing requirements (reference Section 4.1.4).
7. Pressure Systems that do not meet material compatibility requirements specified in Section 4.1.5.2 must contact SpaceX for specific leak testing requirements.



### **3.4.5 FUNCTIONAL TESTING REQUIREMENTS**

For all Payloads, separation detection circuits must be functionally verified before and after dynamic tests to ensure that a Payload does not inadvertently activate during ascent. Subject to SpaceX review, it is acceptable for this test to be coupled with the required vibration tests referenced in Table 3-15.

### **3.4.6 QUALIFICATION - NO TEST CONSIDERATIONS**

Static load qualification requirements may be met in the absence of testing only in the cases where ALL of the following conditions are met and approval is formally granted following a pre-test SpaceX review.

- The structure is entirely metallic and there are no fiber-reinforced or bonded components in the primary load path
- The structural design has simple load paths and the failure modes are well-defined
- The structure is similar in configuration and load conditions to a previously test-verified unit with good post-test correlation to models
- Development and/or component testing has been performed on critical and difficult-to-analyze elements of the structure and good correlation has been demonstrated

In cases where approval is granted, positive structural margins must be analytically demonstrated to the allowable ultimate load at 2.0 times the limit load and the allowable yield load at 1.6 times the limit load. For approval to be granted, the Customer must provide rationale as to how all four no-test conditions are met at the time the request is made.



## 4 PAYLOAD DESIGN AND INTERFACE

### 4.1 PAYLOAD DESIGN REQUIREMENTS

#### 4.1.1 DESIGN FACTORS OF SAFETY

Payload systems and structural components should hold a minimum design factor of safety of 1.40 for all ground operations, and 1.25 for all combined loads seen in flight.

#### 4.1.2 FASTENERS

Any fasteners used on the primary structure or used to hold external components onto the Payload that are removed after acceptance testing must meet the following requirements:

- Fasteners have a diameter of .190 inch (#10 size, metric: 5 mm) or larger.
- Fasteners have a form of retention that is not reliant on preload to function (e.g. prevailing torque feature like distorted thread locking nut or patched fastener, lock wire/lock cable, cotter pin, thread locker with proper application process check, etc.)
- Fasteners be installed by means of an installation procedure that uses a calibrated torque tool, measures installation torque, and verifies retention is functional (e.g. measures prevailing torque and compares to limits, visual verification on lock wire/cable, test coupon for thread locker to test breakaway torque, etc.)
- Fasteners have a minimum acceptable thread protrusion beyond the end of a nut or nut plate of one thread pitch width. This will insure that all of the fully formed threads on the fastener can carry load and that the prevailing torque feature (if present) is engaged properly.

#### 4.1.3 CABLE TIES

All cable ties intended for flight must be non-removable preferably made from Nylon 6/6 or ETFE/Tefzel and must be included in vibration testing. Removable cable ties are only for temporary use during in-process harness routing and must be removed before flight. Contact SpaceX for recommended part numbers.

#### 4.1.4 PRESSURE VESSELS

A pressure vessel is any system containing more than 2000 J of stored energy (pneumatic and chemical energy) or a MEOP greater than 100 PsiD [6.9 barD]. Systems that contain pressure but do not meet the above are considered "pressure components" or "pressure systems".

Pressure vessel classification and use:

- **Type 1:** All metallic. Conforms to AIAA-S-080 (current approved release)
- **Type 2:** Metallic liner with composite hoop. Conforms to AIAA-S-081 (current approved release)
- **Type 3:** Metallic liner with full, wound composite overwrap. Conforms to AIAA-S-081 (current approved release)
- **Type 4:** Non-metallic liner with full, wound composite overwrap. Conform to applicable sections of AIAA-S-081 until such a time as AIAA G-082 is fully released.
  - **Use is not recommended.**
  - **Some restrictions on fluid eligibility apply. See 4.1.4.1.**
- **Type 5:** All-Composite pressure vessels (liner-less)
  - **Use is not recommended.**
  - **Some restrictions on fluid eligibility apply. See 4.1.4.1.**

##### 4.1.4.1 RESTRICTIONS ON PRESSURE VESSEL FLUID USAGE

All hypergolic propellants are ineligible for use in Type 4 and Type 5 pressure vessels. Contact SpaceX for more information.



#### 4.1.4.2 PRESSURE VESSEL LEVEL LEAK TEST

Each individual pressure vessel must undergo leak testing to demonstrate a maximum leak rate of  $10^{-6}$  sccs at MEOP.

For pressure vessels that meet material compatibility requirements stated in Section 4.1.5.2, leak testing can be validated using the following method. Documentation must be submitted to SpaceX in order to evaluate conformance. All non-conforming material compatibility pressure vessels must contact their SpaceX representative for special leak test requirements.

- I. Fully submerge pressure vessel in water
- II. Pressurize to MEOP
- III. Test Fluid: Helium or 90% Nitrogen/10% Helium mix
- IV. Minimum Time duration: 1 hour
- V. Deliverables:
  - Continuous video of full water surface
  - Close-up video of each fitting and connection individually
  - Close-up video of pressure gauge (or data trace)
- VI. Success Criteria: No bubbles

Pressure vessel tests must take proper precautions to ensure safety.

#### 4.1.4.3 US DOT PRESSURE VESSELS

Pressure vessels that are United States Department of Transportation (US DOT) certified and are operated within their published limits and working fluids are strongly preferred over custom vessels.

Verification for US DOT pressure vessels:

- A certificate of conformance from vendor stating vessel maximum design pressure (MDP) including any special permits on the bottle design from vendor.
- A visual of the bottle including the mounting demonstrating a mounting scheme that does not induce significant loading into the bottle (i.e. bottle is not a primary load path for anything besides the bottle itself).

#### 4.1.4.4 NON-US DOT PRESSURE VESSELS

Any pressure vessels that are not US DOT classified require a SpaceX review of qualification and acceptance testing and must meet the following requirements:

- No Type 2,3,4,5 pressurized-structure tanks (reference Section 4.1.4), tanks where non-pressure loading makes up more than 15% of maximum combined flight stress (15% Rule).
- No pressure tanks that require pressure stabilization to hold external structural load.
- Pressurization state of the tank must not change between the time that the Payload is mated to Launch Vehicle hardware and deployment from the Launch Vehicle, as part of the overall Payload inhibit strategy.
- Qualification must include all testing per applicable AIAA document listed in Section 4.1.4 based on pressure vessel type, and AFSPC 91-710 Section 12.
- Pressure vessels must have a contingency pressure relief valve to vent pressure above personnel safe MEOP while in ground operations.
- Pressure vessels must hold burst factors of safety on pressure per applicable AIAA document listed in Section 4.1.4 based on pressure vessel type; not below factors defined in Section 3.4.3 or overall design factors of safety defined in Section 4.1.1 on all combined loading cases. Vessels that carry significant loads beyond pressure (pressurized-structure tanks, secondary structure mounts) must include combined loading in qualification testing and demonstrate testing to the combined factors of safety defined in Section 4.1.1.



#### 4.1.4.4.1 Verification for Non-US DOT Vessels that Meet the 15% Rule

Customer must provide the following:

- Pressure vessel qualification testing including: burst, cycle testing, residual vessel strength after cycle testing, and vibration testing.
- Acceptance testing strategy and per-vessel proof test.
- Combined structural loading analysis in SpaceX template for flight including all loading and material assumptions demonstrating that less than 15% of maximum flight stress is from mounting/external loads (to demonstrate that pressure-only testing is sufficient on the pressure vessel).
- Document detailing test-like-you-fly deviations between test and flight including rationale for acceptance.

#### 4.1.4.4.2 Verification for Non-US DOT Vessels that do NOT meet the 15% Rule

Customer must provide the following:

- **Either:** (Preferred) Static and random vibration qualification of the pressure vessel while pressurized to 1.25 times flight MEOP in flight-like mounting **OR:** analysis report demonstrating complete flight stress coverage between unpressurized vibration/static testing and pressure-only (burst) testing.
- Pressure vessel qualification testing including: burst, cycle testing, residual vessel strength after pressure, and structural cycle testing
- Acceptance testing strategy and per-vessel proof test.
- Document detailing test-like-you-fly deviations between test and flight including rationale for acceptance.

#### 4.1.5 FULLY INTEGRATED PRESSURE SYSTEMS

A pressure system is any system that is intended to be pressurized beyond 0.5 atmospheres. This includes both pressure vessels and pressure components like valves, fittings, and tubes that have potential to see internal pressure in the time between Customer delivery and on-orbit deployment.

For all pressurized systems, the following information must be provided to SpaceX:

1. Document detailing system design criteria, MEOP derivation for flight and ground cases for all pressurized components, features and pressure vessels, including valve set points and relief device sizing.
2. System schematic using standard P&ID symbols and an (excel) tabulated parts list, including valves, reliefs, transducers, and reference designators for all parts.
3. List of all single point failures in the system.
4. Qualification and acceptance testing for each component of the pressure system and the overall system qualification strategy.
5. Document detailing combined system test-like-you-fly deviations between test and flight including rationale.

#### 4.1.5.1 LEAK TEST REQUIREMENT: FULLY INTEGRATED PRESSURE SYSTEM LEVEL

The fully integrated pressure system must be leak tested demonstrating a maximum leak rate of  $10^{-4}$  sccs at MEOP.

For pressure vessels that meet material compatibility requirements stated in Section 4.1.5.2, leak testing can be validated using the following method. Documentation must be submitted to SpaceX in order to evaluate conformance. All non-conforming material compatibility pressure vessels must contact their SpaceX representative for special leak test requirements.

- I. Pressurize fully integrated system to MEOP
- II. Test Fluid: Helium or 90% Nitrogen/10% Helium mix
- III. Coat all fittings/connections with Snoop (ask SpaceX representative to verify acceptable equivalents)
- IV. Deliverables:
  - a. Close up video of each fitting and connection individually
  - b. Close up video of pressure gauge (or data trace)



- V. Success Criteria: No bubbles

Pressure system tests must take proper precautions to ensure safety.

#### **4.1.5.2 MATERIAL COMPATIBILITY ASSESSMENT**

All Customers must provide a comprehensive list of pressure system materials for a compatibility assessment.

The list must include:

- I. All pressure system materials within the pressure vessel, and all other pressurized components
- II. All working fluids, processing fluids, and expected/potential by-product fluids

Accepted material compatibility are per the following industry accepted design guide:

- "Material Compatibility with Space Storable Propellant. Design Guidebook," P.E. Uney, et al, Martin Marietta Corporation. March 1972.

Any material combinations that are outside of this specification require SpaceX approval and may require modifications to testing as stated herein.



## 4.2 MECHANICAL INTERFACES

### 4.2.1 LAUNCH VEHICLE COORDINATE FRAME

The Launch Vehicle uses a right-hand X-Y-Z coordinate frame, indicated with the subscript "LV", centered 440.69 cm (173.5 in.) aft of the first-stage radial engine gimbal, with  $+X_{LV}$  aligned with the vehicle long axis and  $+Z_{LV}$  opposite the TE strongback as shown in Figure 4-1.  $X_{LV}$  is the roll axis,  $Y_{LV}$  is the pitch axis, and  $Z_{LV}$  is the yaw axis.



Figure 4-1: Launch Vehicle Coordinate Frame

### 4.2.2 LAUNCH VEHICLE FAIRING

The total available volume shared by both Payload and Co-Payload(s) is shown in Figure 4-2. All processing requiring access to the Payload must be completed prior to fairing encapsulation including remove/install-before-flight items.

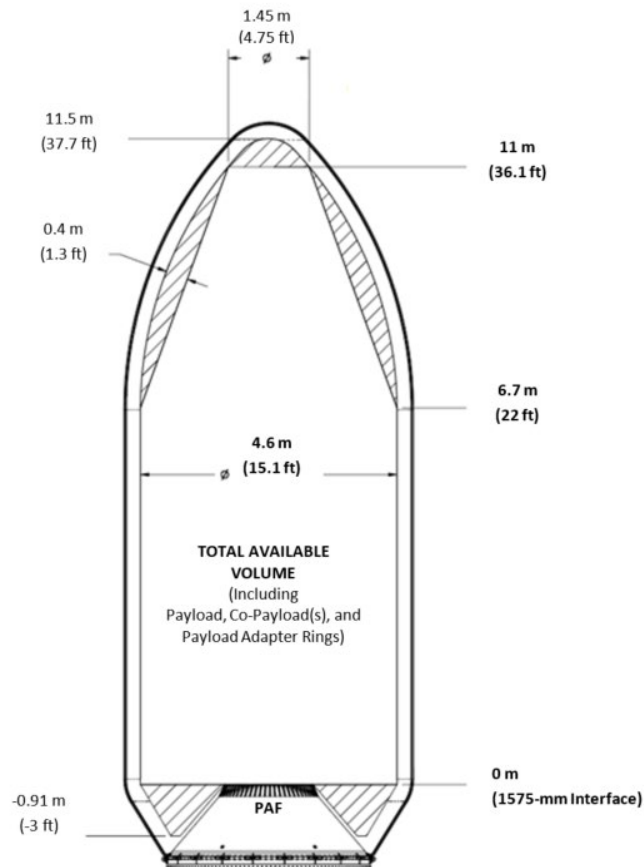


Figure 4-2: Total Available Fairing Volume



### 4.2.3 PAYLOAD COORDINATE FRAME

The origin of the Payload coordinate system is fixed at the center of the mechanical interface between Customer-supplied hardware and SpaceX-supplied hardware. The Payload will use a right-hand X-Y-Z coordinate system, indicated with a subscript "PL" with  $X_{PL}$  in the Payload axial direction as described in Section 4.2.5.

### 4.2.4 STANDARD MECHANICAL INTERFACES

SpaceX provides standard mechanical interfaces between Launch Vehicle hardware and Customer-provided hardware. SpaceX will provide 8", 15" and 24" diameter standard interfaces per the specifications identified in Appendix A. This interface will be provided, either directly to the Rideshare Plate or via a SpaceX-provided adapter, at SpaceX's discretion.

Customer is responsible for providing the fasteners that directly mate to their interface, along with a corresponding fastener structural analysis that validates their fastener selection. For standard bolt circle interfaces, the Payload will mechanically interface to the Launch Vehicle hardware via 0.25" diameter 28 threads-per-inch fasteners. The number of fasteners will be dependent on the diameter of the bolt circle. See Appendix A for specifications. Customer-provided fasteners must be compliant with the requirements defined in Section 4.1.2, including minimum acceptable thread protrusion.

SpaceX is responsible for the final mate to the Launch Vehicle hardware. Non-standard mechanical interfaces can be accommodated by using an adapter provided by SpaceX as an optional service (see Appendix I). For non-standard interfaces, including CubeSat deployers, please contact SpaceX.

### 4.2.5 PAYLOAD AVAILABLE VOLUME

Payloads must be confined to the available volumes defined in the following sections. When mated in the Rideshare Plate configuration, the Payload  $X_{PL}$  axis is horizontal when the Launch Vehicle is vertical on the Launch pad. When mated in the Starlink adapter configuration, the Payload  $X_{PL}$  axis is vertical when the Launch Vehicle is vertical on the Launch pad.

#### 4.2.5.1 RIDESHARE PLATES

##### 4.2.5.1.1 RIDESHARE PLATE CONFIGURATIONS

Rideshare Plates can be arranged in a hexagon shape, comprised of six (6) modular plates, or they can be arranged in a cube shape, comprised of four (4) modular plates as shown in Figure 4-3. Each Rideshare Plate could have unique Payload accommodations. The cube configuration, due to its lower profile geometry, provides increased radial volume for Payloads.

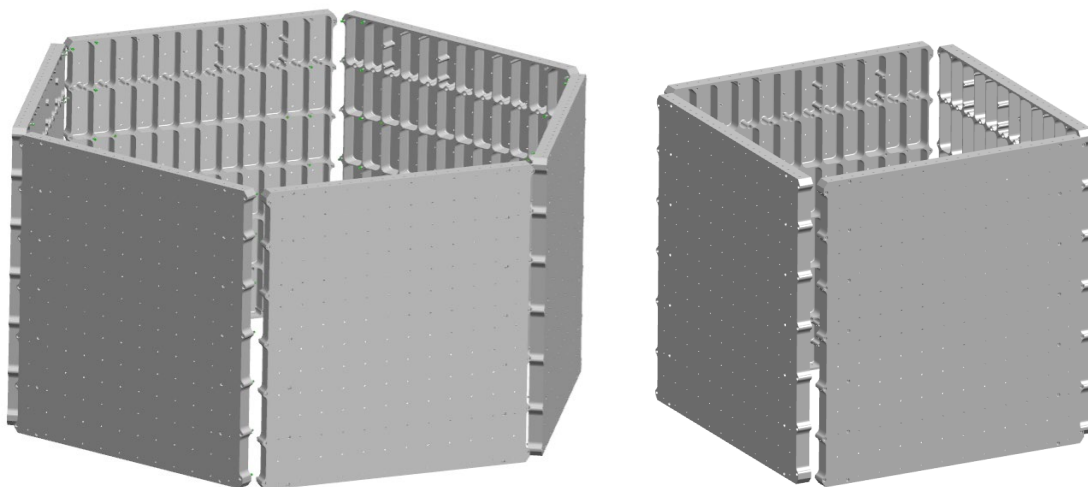


Figure 4-3: Rideshare Plates - Hexagon Configuration (Left) and Cube Configuration (Right)

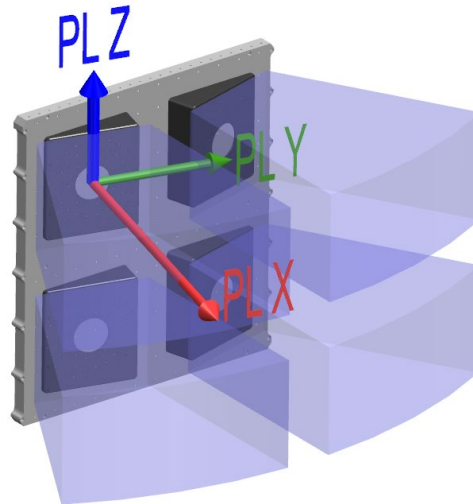




#### 4.2.5.1.2 RIDESHARE PLATE VOLUME OPTIONS

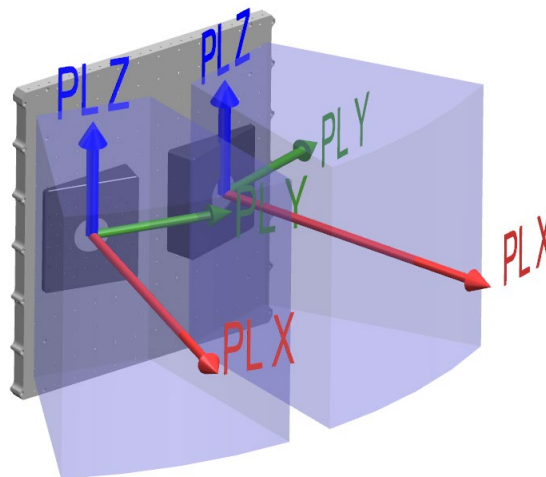
Payload volumes vary depending on the Rideshare Plate configuration (hexagon vs. cube as stated above) and by the portion of the plate used. Rideshare Plates can accommodate a variety of mechanical interfaces broken down into  $\frac{1}{4}$  Plate,  $\frac{1}{2}$  Plate, Full Plate, and Full Plate (XL Volume) sized volumes. Detailed dimensions can be found in Appendix A.

The  $\frac{1}{4}$  Plate available volume can accommodate 8" diameter, or equivalent, sized interfaces with an allowable volume as shown in Figure 4-4 and will be part of a hexagon configuration.



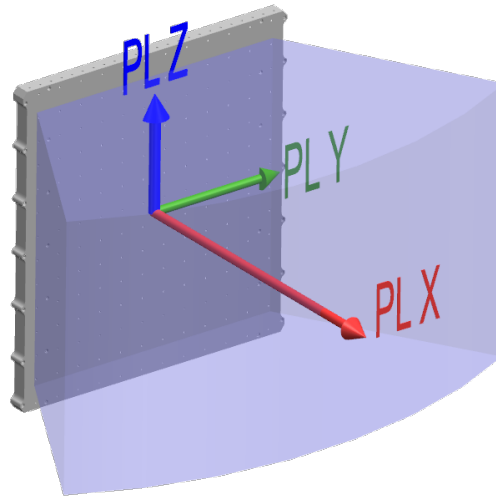
**Figure 4-4: Rideshare Plate –  $\frac{1}{4}$  Plate Available Volume**

The  $\frac{1}{2}$  Plate available volume can accommodate both 8" and 15" diameter, or equivalent, sized interfaces with an allowable volume as shown in Figure 4-5 and will be part of a hexagon configuration of Rideshare Plates.

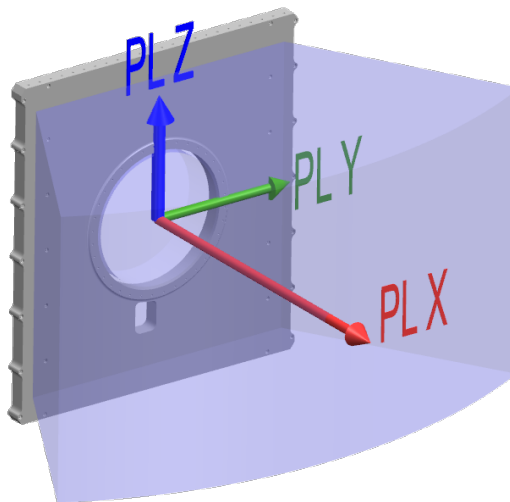


**Figure 4-5: Rideshare Plate –  $\frac{1}{2}$  Plate Available Volume**

The Full Plate available volume can accommodate both 15" and 24" diameter, or equivalent, sized interfaces with an allowable volume as shown in Figure 4-6 and will be part of a hexagon configuration of Rideshare Plates. For a single Payload with a 24" diameter interface there is an allowable 177.8 mm intrusion through the SpaceX-provided mechanical interface as shown in Figure 4-7.

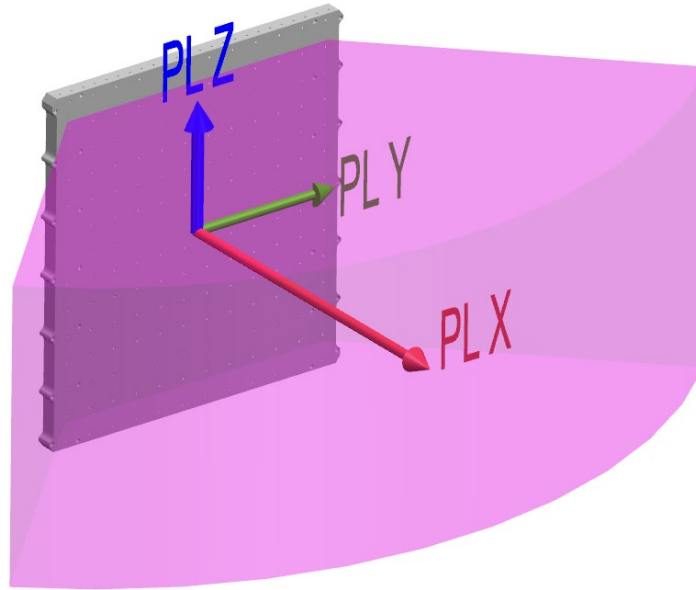


**Figure 4-6: Rideshare Plate – Full Plate Available Volume**

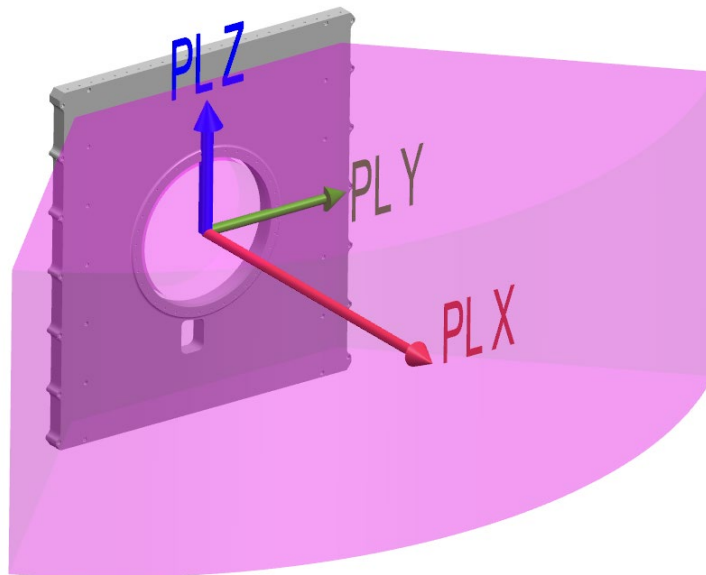


**Figure 4-7: Rideshare Plate – Full Plate including Internal Available Volume**

The Full Plate (XL Volume) available volume can accommodate a 24" diameter, or equivalent, sized interface with an allowable volume as shown in Figure 4-8 and will be part of a cube configuration of Rideshare Plates. For a single Payload with a 24" diameter interface there is an allowable 177.8 mm intrusion through the SpaceX-provided mechanical interface as shown in Figure 4-9.

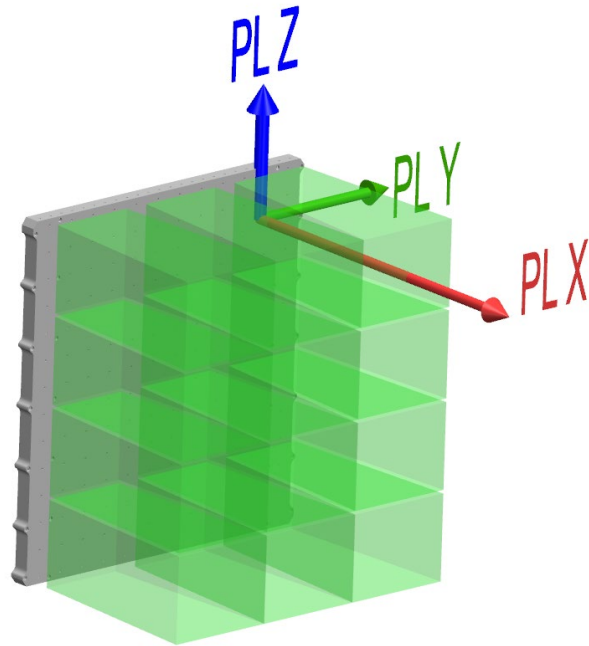


**Figure 4-8: Rideshare Plate – Full Plate (XL Volume) Available Volume**



**Figure 4-9: Rideshare Plate – Full Plate (XL Volume) including Internal Available Volume**

Finally, CubeSat dispensers can be accommodated on a unique Rideshare Plate with an allowable volume as shown in Figure 4-10 and will be part of a hexagon configuration or Rideshare Plates.

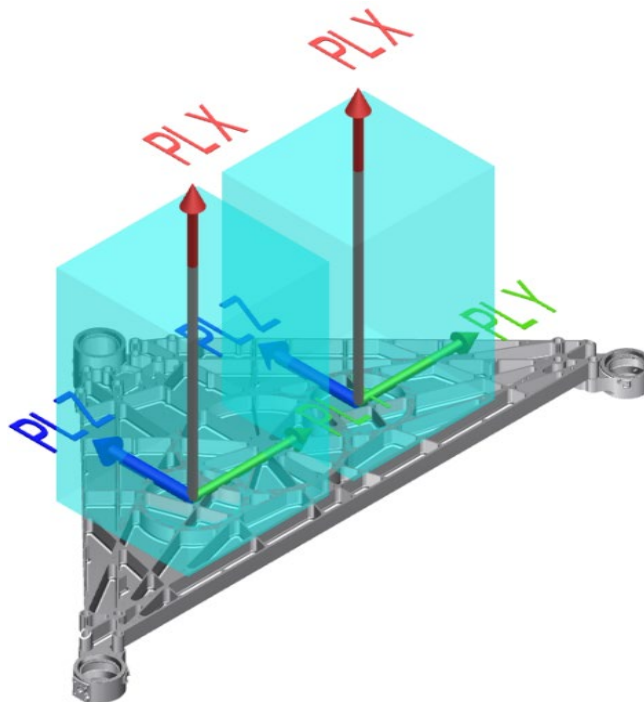


**Figure 4-10: Rideshare Plate – Example CubeSat Dispenser Available Volume**

**4.2.5.2 STARLINK ADAPTER**

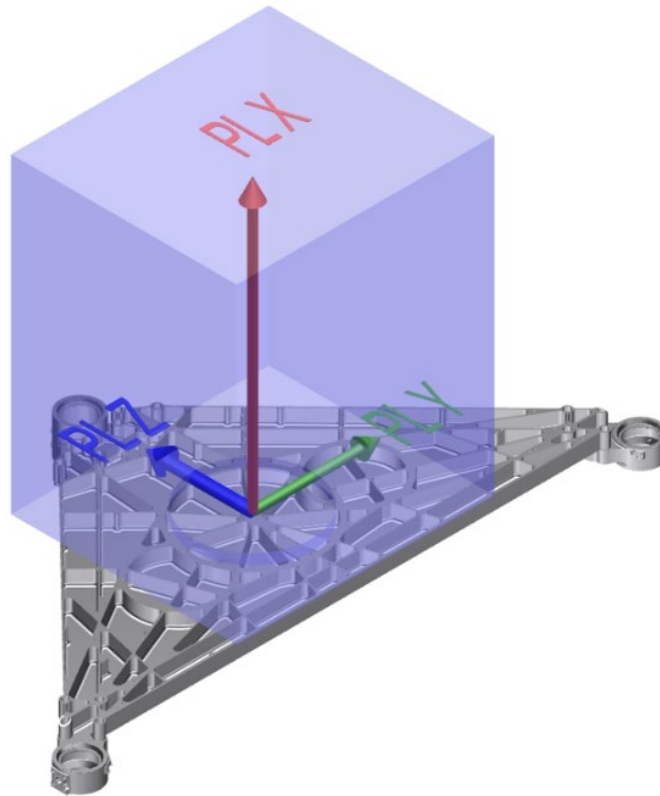
A Starlink adapter plate can accommodate either two (2) 15" diameter Rideshare Payloads or one (1) 24" diameter Rideshare Payload. Detailed dimensions can be found in Appendix A.

A Payload mated to a 15" diameter mechanical interface has an allowable volume as shown in Figure 4-11. In addition, there is an allowable 38 mm intrusion through the mechanical interface.



**Figure 4-11: Starlink Adapter - 15" Diameter Payload Available Volume**

A Payload mated to the 24" diameter mechanical interface has an allowable volume as shown in Figure 4-12. In addition, there is an allowable 38 mm intrusion through the mechanical interface.



**Figure 4-12: Starlink Adapter 24" Diameter Payload Available Volume**

#### **4.2.6 MECHANICAL INTERFACE COMPATIBILITY**

SpaceX, in its sole discretion, may provide access to the Launch Vehicle mechanical interface to support a Payload-to-Launch Vehicle mechanical fit check at the Launch Site before flight mating. The fit check will confirm the mechanical compatibility of the SpaceX-provided mechanical interface and the Customer Payload interface and, optionally, the mechanical alignment of the umbilical connectors as documented in the Payload-specific ICD.

### **4.3 ELECTRICAL INTERFACE**

The Launch Vehicle provides electrical connectivity between the Payload and Customer-provided EGSE prior to Launch. During Launch, the Launch Vehicle provides in-flight separation device initiation and separation. Other Payload commands or interleaved telemetry access is not provided as a standard service.

#### **4.3.1 STANDARD OFFERING INTERFACE**

The Launch Vehicle provides an electrical bulkhead located next to each mechanical interface where a Payload is mounted. This bulkhead exposes all of the channels that will be used by the Payload for the Mission. The bulkhead consists of several MIL-STD-1560 connectors which will be specified as part of the Payload-specific ICD.

The number of channels provided by the Launch Vehicle varies based on the type of channel and mechanical interface. Table 4-1 summarizes the minimum allocation of each channel type.

**Table 4-1: Standard Offering Interface - Maximum Channel Allocation**

Channel Type <sup>1,2</sup>	Rideshare Plate					Starlink Adapter	
	¼ Plate	½ Plate	Full Plate	Full Plate (XL Volume)	CubeSat Dispenser	15" Payload	24" Payload
Primary Deployment (# channels)	1	2	6	8	4	2	4
Secondary Deployment (# channels)	1	2	6	8	4	2	4
Breakwire (PL-side loopback) (# channels)	2	4	12	16	8	2	4
Umbilical Group (# channel groups)	1	1	1	1	0	2	4

Notes:

1. The number of channels and channel groups listed in Table 4-1 are the maximum available for a given configuration. Default channel allocations for one contract will be for a single Payload deployment.
2. Additional channels, beyond those needed for a single Payload deployment, of primary deployment, secondary deployment, breakwire signals, and in some cases, up to one (1) additional umbilical group, are available as an optional service as described in Appendix I, within the limitations of Table 4-1.

#### 4.3.2 DEPLOYMENT CHANNEL PROPERTIES

Deployment channels are offered in pairs of primary and secondary commands. One primary and one secondary command must be used for each actuation.

All deployment/separation devices directly interfacing with Launch Vehicle electrical systems must have sufficient reliability to ensure safe deployment. The preferred method of achieving reliability is two independent actuators on separate circuits. Either of these actuators must be capable of independently initiating Payload separation, effectively removing a single point of failure to Launch Vehicle separation. Exceptions to this method are discouraged but can be considered on a case-by-case basis at SpaceX's sole discretion.

All deployments from the Launch Vehicle will be commanded by SpaceX. The use of Customer-provided sequencers for commanding more than one deployment from the Launch Vehicle within the Payload is prohibited.

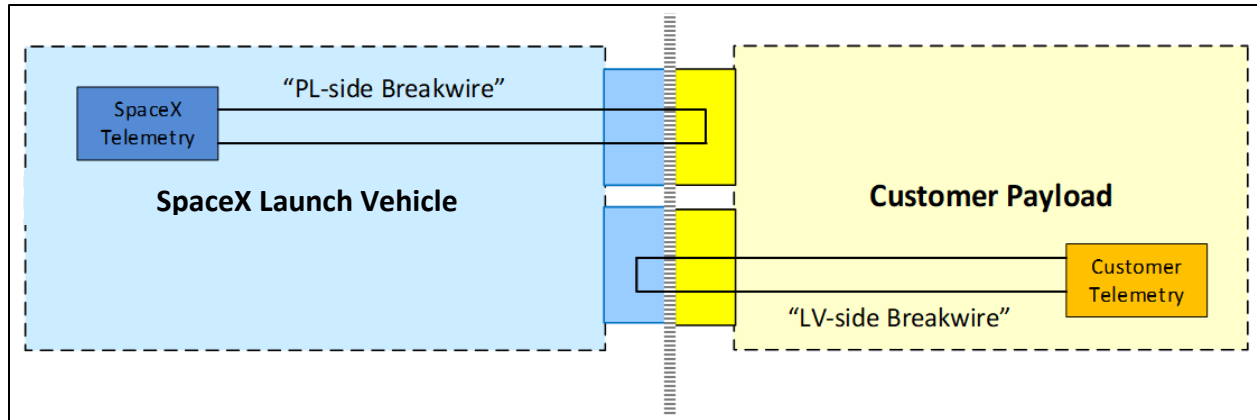
Each deployment command sent by the Launch Vehicle can be configured in one of two ways:

1. Constant-Current Pulse: Used for low-resistance loads, this mode of operation provides up to 6 A of constant current. Specifics of the pulse duration and current setting will be specified as part of the Payload-specific ICD.
2. Bus-Voltage Pulse: Used for high-resistance or motor-driven loads, this mode of operation will provide an unregulated voltage signal between 24-36 V with a maximum current draw of 6 A. Specifics of the pulse duration will be specified as part of the Payload-specific ICD.

The specific configuration of the deployment commands will be determined by SpaceX through analysis and testing of each separation device. The deployment device timing delay from receipt of the Launch Vehicle deployment signal to physical release of the Payload is required to be characterized as < 2 seconds ± 0.5 second uncertainty.

#### 4.3.3 BREAKWIRE CHANNEL PROPERTIES

Breakwire channels are used to determine separation status of the Payload Constituents from the Launch Vehicle. Breakwires are organized into two categories, "PL-side breakwires" which are used by the Launch Vehicle to detect separation and "LV-side breakwires" which are used by the Payload to detect separation. This is illustrated in Figure 4-13.



**Figure 4-13: Illustration of Breakwire Channel Categories**

A minimum of one (1) PL-side breakwire is recommended to be used for each deployment from the Launch Vehicle, SpaceX will evaluate exceptions on a case by case basis. There are no restrictions from SpaceX on the number of LV-side breakwires requested by the Customer.

PL-side breakwire channels must transition from a low resistance state to a high resistance state, or vice-versa. Table 4-2 defines the required properties of each state.

**Table 4-2: PL-side breakwire resistance requirements**

PL-side Breakwire State	Resistance requirement
Low-resistance state	<200 $\Omega$
High-resistance state	>8 k $\Omega$

It is acceptable for either loopback circuits or separation switches to be used for PL-side and LV-side breakwires. The final properties of the PL-side breakwire circuit(s), including the expected transition during deployment, will be captured as part of the Payload-specific ICD.

#### 4.3.4 UMBILICAL CHANNEL PROPERTIES

Umbilical channels offer connectivity between the Payload and Customer EGSE systems. Umbilical channels are offered in “umbilical groups” consisting of six (6) channels. The transmission properties of each of these channels is specified in Table 4-3.

**Table 4-3: Umbilical Channel Electrical Properties**

Umbilical Channel Name	Example Usage	Maximum One-Way Resistance ( $\Omega$ )	Maximum Allowable Steady-state Current (A)	Controlled Characteristic Impedance
BATT_CHG_1	Battery charging	5	3.5	--
BATT_CHG_2				
BATT_SNS_1	Battery sensing	13.5	3.5	--
BATT_SNS_2				
COMM_1	Communication	18	2.5	100 $\Omega$
COMM_2				

The “example usage” column in Table 4-3 represents the expected usage of the channel, but is not a requirement. The Customer can use the umbilical signals as required for the Payload, with the following restrictions:

- The electrical properties of the signal must be de-rated to the advertised capabilities of the cable.
- No AC signals may be transmitted.



#### 4.3.5 FLIGHT HARNESS DESIGN

The build responsibility for the harnesses between the Standard Offering Interface and Payload (hereafter referred to as “Customer-specific harnessing”) will be specified as part of the Payload-specific ICD. In general, any harness containing deploy signals will be built by SpaceX, while any harness that exclusively has breakwire and/or umbilical signals will be built by the Customer.

For Customer-specific harnessing built by SpaceX, SpaceX may require the Customer to send SpaceX the flight connectors at the Payload interface.

For Customer-specific harnessing built by the Customer, SpaceX will send the Customer the required flight connectors to interface at the Standard Offering Interface. Customer-specific harnessing built by the Customer must be designed and built in accordance with the Wire Harness Build Guide provided by SpaceX as part of the mission integration process.

In all instances, details of the harness design, including length and routing path, will be determined through routing review meetings between SpaceX and the Customer and documented as part of the Payload-specific ICD.

#### 4.3.6 CONNECTIVITY DURING PAYLOAD PROCESSING

SpaceX accommodates electrical connectivity between Customer EGSE and the Payload during standalone processing. Electrical interfaces will not be available during SpaceX adapter mate, encapsulation, Launch Vehicle integration, and rollout operations. Between these steps Customer may elect additional connectivity as an optional service as described in Table 4-4.

**Table 4-4: Payload Electrical Interface Connectivity**

Phase	Interface Connection	Note
Payload processing (in PPF)	Customer cables directly to Payload	Included
Mate (in PPF)	None	--
Encapsulated (in PPF)	Customer cables to PPF junction box or equivalent interface	Optional Service
Transport to hangar	None	--
Pre-integration (in Hangar)	None	--
LV integration (in Hangar)	None	--
on TE (in Hangar)	Customer cables to hangar junction box or equivalent interface	Optional Service
Rollout	None	--
On pad	Customer cables to pad junction box or equivalent interface	Optional Service
Flight	Separation initiation and indication only	Included

The Launch Vehicle does not provide power to Rideshare Payloads during Launch operations. Payload batteries must be switched off during Launch. An exception may be made for batteries in standby mode with closed circuit architecture if test results provided to SpaceX verify spurious emissions meet the requirements defined in Section 3.3.7.

#### 4.3.7 GROUND HARNESS DESIGN

If the Payload is charging in the Launch Vehicle hangar, Customer is expected to provide a 6.1-m (20-ft) harness to connect the Payload EGSE to SpaceX ground systems. SpaceX will supply the Payload EGSE-side electrical connector(s) and any required accessories.

The maximum total cable lengths between the Payload EGSE and the SpaceX payload attach fitting pass through bulkhead are listed in Table 4-5. The total cable length between Payload EGSE and the Standard Offering Interface will be determined during Mission design. The general path is shown in Figure 4-14.

**Table 4-5: Maximum Expected Cable Lengths between Payload EGSE and Payload Electrical Bulkhead**

Launch Site	PPF	Hangar
VSFB (SLC-4)	37 m (120 ft.)	207 m (679 ft.)
CCSFS (SLC-40)	24.5 m (80 ft.)	196.5 m (644 ft.)
KSC (LC-39A)	24.5 m (80 ft.)	180 m (589 ft.)



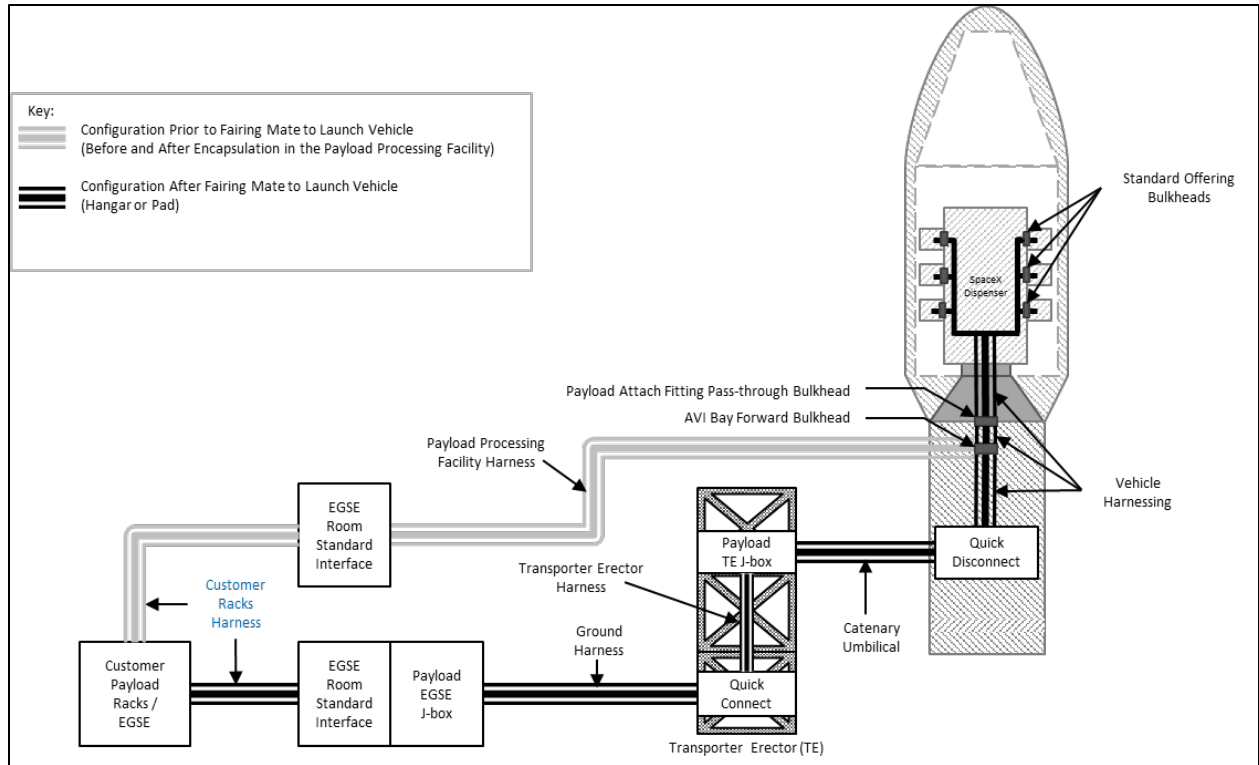


Figure 4-14: Ground Side Electrical Interfaces

#### 4.3.8 TIMING SERVICES

SpaceX can supply inter-range instrumentation group IRIG-B000 or IRIG-B120 time from its GPS clocks to Customer EGSE at the PPF.

#### 4.3.9 ELECTRICAL INTERFACE COMPATIBILITY

SpaceX may in its sole discretion require an electrical compatibility test between Launch Vehicle avionics and separation devices. This test will confirm the ability of the Launch Vehicle to initiate and detect separation and will use flight-like systems for both the upstream firing circuit and downstream separation system.



## 5 LAUNCH SITE FACILITIES

SpaceX operates Launch Sites at:

- Space Launch Complex 40 (SLC-40) at Cape Canaveral Space Force Station (CCSFS), Florida
- Launch Complex 39A (LC-39A) at John F. Kennedy Space Center (KSC), Florida and
- Space Launch Complex 4 East (SLC-4E) at Vandenberg Space Force Base (VSFB), California.

Details about these Launch Sites can be found in the SpaceX Falcon User's Guide, latest revision, available at [www.spacex.com/vehicles/falcon-9/](http://www.spacex.com/vehicles/falcon-9/).

SpaceX will provide the Launch Site facilities, equipment, documentation, and procedures to receive Customer's hardware, validate interfaces to Customer's hardware, integrate the Payload with the Launch Vehicle, and perform a Launch of the Payload.

### 5.1 FACILITY ACCESS AND WORKING HOURS

SpaceX supports Customer personnel access to Launch Site facilities for two eight-hour working shifts per day, during those portions of the Launch Campaign when Customer's activities require use of a given facility.

SpaceX additionally supports 24/7 access to Launch Site facilities on an as-needed basis for Customer's scheduled activities throughout the campaign, provided such access is coordinated in advance and mutually agreed with SpaceX. SpaceX supports 24/7 access (24 hours per day, 7 days per week) to Launch Site facilities for responding to emergency or off-nominal situations related to flight hardware.

During the Launch Campaign, SpaceX may provide short-term, controlled facility access to SpaceX personnel, SpaceX's contractors, or other third parties (e.g., other customers, potential customers, VIPs, SpaceX-hosted tours). SpaceX is not required to provide Customer advance notice for short-term, controlled access to areas free of Payload or Customer's hardware. SpaceX will provide prior notice and request approval for physical or visual access to areas with Payload or Customer's hardware. At all times, SpaceX will follow Customer proprietary information and security requirements.

### 5.2 CUSTOMER OFFICES

SpaceX provides an office area at the Launch Site during Payload processing. The office area could be shared with Co-Payload Customer(s) and could be located at the PPF or a nearby SpaceX facility. Office accommodations include 100-Mbps-class Internet connection, which may be common with other Customer Internet connections, air conditioning, and standard office equipment such as desks chairs and phones.

### 5.3 SPACEX PAYLOAD PROCESSING FACILITY (PPF)

SpaceX provides a PPF at the Launch Site for the Customer to perform Payload pre-Launch processing activities. Payload and Co-Payload(s) may be co-located in the processing area. The processing area will be defined in a Mission-specific Launch Campaign Plan based on Payload and Co-Payload(s) space requirements. The Payload processing area will:

- Operate at ISO 14644-1 Class 8 (Class 100,000) cleanliness.
- Operate at 70 °F ± 5 °F air temperature (21 °C ± 3 °C).
- Operate at 45% ± 15% relative humidity.
- Include 30-ton and 10-ton capacity cranes with 100 ft. (30 m) hook height.
- Provide a designated floor space for Payload processing activities defined in the Payload-specific ICD.

The PPF includes an area for Payload EGSE adjacent to the Payload processing area. A 100-Mbps-class Internet connection is provided, which may be common with other Customer Internet connections.



#### **5.4 LAUNCH COMPLEX**

SpaceX provides a Launch Complex including the Launch pad, and related Launch Vehicle GSE. SpaceX provides conditioned air into the fairing including environmental monitoring of the encapsulated Payload when at the Launch pad. In the event of a Launch Site power outage, conditioned air will be resumed on backup power systems within 10 minutes.

#### **5.5 LAUNCH COUNTDOWN MONITORING**

SpaceX may provide Customer personnel (determined on an as-needed basis) a space at the Launch Site for Launch countdown monitoring. Space will be shared between Payload and Co-Payload Customer(s), as documented in the Mission-specific Launch Campaign Plan.



## 6 MISSION INTEGRATION AND SERVICES

### 6.1 CONTRACTING

Rideshare Launch Services are available via direct contract with SpaceX and through certain managed procurement services. To begin your direct contract relationship with SpaceX, please visit [www.spacex.com/rideshare](http://www.spacex.com/rideshare).

### 6.2 US EXPORT AND IMPORT CONTROL LAWS

Provision of all items, information, and services identified in the Agreement by SpaceX to any foreign person (including Customer and/or Customer's Related Third Parties, if applicable) is subject to US export control laws, including the ITAR, administered by the US Department of State, and EAR, administered by the US Department of Commerce. Customer must comply with US export and import control laws, including clearance from US Customs and Border Protection, with respect to the Payload and any Customer provided hardware, including GSE and propellant (if any).

If SpaceX reasonably determines that obtaining a License by either Party is not possible or highly unlikely within a reasonable amount of time, despite commercially reasonable efforts by both parties to do so, SpaceX reserves the right to re-book Customer, with applicable rebooking fees, or terminate the Agreement and return all amounts paid to Customer, without interest, with no further liability.

### 6.3 MISSION MANAGEMENT

To streamline communication and ensure customer satisfaction, SpaceX provides each Launch Services Customer with a single technical point of contact from contract award through Launch (Figure 6-1). Your mission manager will be responsible for coordinating Mission integration analysis and documentation deliverables, planning integration meetings and reports, conducting mission-unique analyses and coordinating all integration and test activities associated with the Mission. The mission manager also coordinates all aspects of Launch Vehicle production, range and range safety integration, and all Mission-required licensing leading up to the Launch Campaign. The mission manager works closely with the Customer, SpaceX technical execution staff and all associated licensing agencies in order to achieve a successful Mission.

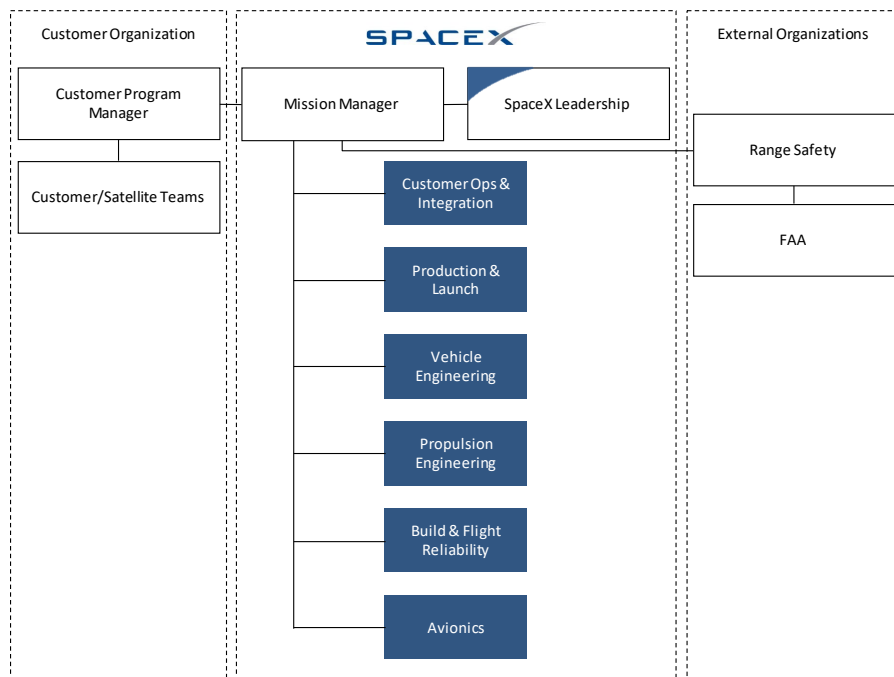


Figure 6-1: Mission Management Organization



## **6.4 PROGRAM DOCUMENTATION**

### **6.4.1 INTERFACE CONTROL DOCUMENT (ICD)**

SpaceX creates and maintains the Payload ICD in conjunction with Customer inputs. The Payload ICD will be negotiated in good faith between the Parties and at a minimum define physical interfaces (mechanical and electrical), functional requirements (orbit, attitude, etc.), Payload MPEs, and Launch operations requirements. Following signature by SpaceX and Customer, the Payload ICD will take precedence (in the event of a conflict) over the Statement of Work. Prior to signature, the Payload ICD is maintained in draft. SpaceX will deliver the Payload ICD for signature following the completion of Mission integration analyses. Once delivered for signature, the Parties will work in good faith to promptly sign the Payload ICD.

### **6.4.2 LAUNCH CAMPAIGN PLAN**

SpaceX provides a Launch Campaign Plan and schedule of Launch Site operations, including required delivery dates for Launch Range-related documentation. SpaceX will coordinate with the Customer to integrate Launch Vehicle and Payload timelines into this plan.

### **6.4.3 PROGRAM STATUS, MEETINGS, WORKING GROUPS AND REVIEWS**

SpaceX will provide program status and conduct meetings, working groups and reviews as described in the following subsections. SpaceX will provide advance copies of deliverables, as noted; otherwise, deliverables will be provided at the time of the corresponding event.

#### **6.4.3.1 INTEGRATION WORKING GROUPS**

SpaceX will organize integration working group meetings on an as-needed basis to address specific issues or operations related to integration of the Payload with the Launch Vehicle. The meeting schedules and locations will be mutually agreed between the Parties.

#### **6.4.3.2 PROGRAM REVIEWS AND MILESTONES**

SpaceX will hold a program review to discuss Launch Campaign readiness at the completion of the Mission integration analysis cycle. Program milestones and timeline are defined in the Payload contract's Statement of Work.

## **6.5 CUSTOMER RESPONSIBILITIES**

Customer responsibilities include the following items. Timely completion is necessary to ensure that SpaceX can fulfill its responsibilities and obligations described in Section 6.6. The Parties understand that any material failure by Customer to meet its responsibilities, including any non-compliance with the Payload ICD, may result in a Customer delay requiring rebooking with applicable fees.

### **6.5.1 TRANSPORTATION**

- Customer is responsible for delivering the Payload and associated GSE to the PPF or other Launch Site facility designated by SpaceX. Customer remains responsible for environmental control of the Payload during Payload delivery, until the Payload is removed from its shipping container, including generators and fuel to maintain environmental control.
- Customer delivers the Payload and GSE to the Launch Site no more than six weeks prior to the Launch Date unless requested by SpaceX. Timing of delivery will be coordinated by SpaceX based on Payload and Co-Payload(s) processing schedule.
- Customer arranges and executes the shipment of the Payload shipping container and all Customer-furnished GSE from the Launch Site no later than three days after Launch.
- Customer is responsible for all shipping and logistics of hazardous items from the port of entry to the Launch Site, including the required labeling for storage at the Launch Site.



- Customer is responsible for obtaining any required permits, Licenses, or clearances, including from U.S. Customs and Border Protection for Customer's and Customer's Related Third Parties' hardware and consumables.

### 6.5.2 HARDWARE, PROCESSING AND INTEGRATION

- Customer provides the Payload and all Payload-unique GSE required for Customer's Launch readiness activities at the Launch Site, interfacing to SpaceX hardware at the Launch Site (as defined in the Payload ICD), and ensure that all Payload and Payload-unique GSE meet the appropriate safety requirements, reference Section 8.1.
- Customer will coordinate activities with SpaceX to create an integrated schedule and procedures where necessary.
- Beginning upon Payload arrival at the Launch Site and throughout the Launch Campaign, Customer provides to SpaceX once per working day, an updated Payload processing schedule. The schedule should include a three day look-ahead summarizing all items requiring SpaceX support, such as: opening processing area doors, SpaceX GSE usage (cranes, forklifts, man lifts, etc.), and any other items requiring SpaceX support. Note also, Payload hazardous operations require 72 hours' advance notice, with precise activity timing, from SpaceX to the Launch Range safety authorities.
- Upon request, Customer will provide SpaceX with access to the flight-mating interface for a mating interface to SpaceX-provided Mechanical Interface fit check after Payload arrival at the Launch Site but before flight mating.
- Customer is responsible for providing all personal protective equipment, such as fall protection harnesses, for Customer and Customer's Related Third Parties at the Launch Site. Customer and Customer's Related Third Parties may not borrow personal protective equipment from SpaceX personnel.
- Customer is responsible for cleaning all Customer-provided equipment and hardware to the appropriate SpaceX-designated contamination-control levels prior to entering SpaceX's cleanliness-controlled facilities at the Launch Site (e.g. the PPF). Standard cleaning products (e.g. isopropyl alcohol and cleanroom wipes) are provided by SpaceX; however, SpaceX personnel will not clean Customer hardware.
- The Payload will not have RF transmissions once mated to Launch Vehicle hardware until after Payload separation as defined Section 3.3.7.2. Any Payload RF checkouts required at the PPF must be contained within the processing area referenced in Section 5.3. Timeline for any approved checkouts will be documented in the Launch Campaign Plan.
- The Payload will have access to the electrical harnesses referenced in Section 4.3 for Payload health checks and battery charging up until Launch Vehicle rollout from the integration hangar to the Launch pad. Additional access to Payload telemetry and battery charging can be procured as an optional service (see Appendix I).

### 6.5.3 HAZARDOUS PROCEDURES

Fueling of Rideshare Payloads at the Launch Site is available as an optional service (see Appendix I), but not part of the standard offering.

- Customer will provide any pressurant and other consumables required by the Payload, including transportation of such consumables to and from the Launch Site. Delivery of all Payload consumables must be coordinated in advance with SpaceX.
- Customer will provide advance copies of all hazardous operation procedures, in addition to a Payload GOP (Ground Operations Plan) which references each hazardous procedure (reference Appendix G). Hazardous procedures and the GOP are reviewed and approved by the Launch Range safety authority. Customer will also provide copies of any non-hazardous procedures requested by the Launch Range safety authority.
- Customer will arrange for and implement the disposal of hazardous waste generated during Payload processing activities in accordance with Launch Range and facility regulations.



- Customer will provide the necessary decontamination equipment and perform all required decontamination activities for Payload GSE that is contaminated by hazardous substances during Payload processing activities in accordance with Launch Range and facility regulations.

#### **6.5.4 ENTRY AND EXIT VISAS**

Customer is responsible for obtaining any visas required for Customer's personnel; including Customer's Related Third Parties and guests. SpaceX can provide letters of invitation for Customer's Launch Campaign personnel to support the issuance of U.S. entry visas by the U.S. Department of State.

#### **6.5.5 ANOMALY, MISHAP, ACCIDENT OR OTHER EVENT**

In the event of an anomaly, mishap, accident or other event resulting in property damage, bodily injury or other loss, Customer will cooperate with SpaceX, any insurers, and federal, state and local government agencies, in their respective investigations of the event, including the completion of witness statements, if applicable. Such cooperation will include providing all data arising out of or related to the Payload, any ground support, and any activities relating to the performance of the Agreement, reasonably requested by SpaceX, the insurers, or federal, state and local agencies. Notwithstanding Customer's obligation to cooperate, SpaceX may use reasonable means to independently access such information. Customer and Customer's customers may not make any public comment, announcement, or other disclosure regarding such event without SpaceX's review and approval.

#### **6.5.6 PAYLOAD LICENSING AND REGISTRATION**

Customer will flow down its responsibilities relating to Payload licensing and registration under the Agreement (including registration pursuant to the Convention on Registration of Objects Launched into Outer Space) to each of its customers, in writing. Evidence of proper flow-down will be provided to SpaceX upon request. Customer will provide a letter in the form of Appendix F, certifying that Customer has obtained all required Licenses and that all Payload information provided to SpaceX and/or any licensing agencies is complete and accurate.

#### **6.5.7 COORDINATION WITH SPACE SITUATIONAL AWARENESS AGENCIES**

Customer is responsible for registering all deployed objects with the 18<sup>th</sup> SPCS to assist with the tracking and identification of all deployed Payload Constituents. More information can be found at <https://www.space-track.org> on how to register a Payload and the process for communicating and coordinating with the 18<sup>th</sup> SPCS. If required, SpaceX can provide direct contact information with personnel from the 18<sup>th</sup> SPCS.

To further aid in U.S. Space Force satellite tracking, identification, cataloging and collision avoidance screening, SpaceX strongly recommends customers publish forward predicted satellite ephemerides and covariance to <https://www.space-track.org> as quickly as possible post Launch. If Customer is unable to generate propagated ephemeris and covariance SpaceX strongly recommends they work with a commercial provider (SpaceX can provide recommendations) to contract for this work. Publishing predicted ephemerides and covariance drastically improves and accelerates the cataloging process by USSPACECOM, as well as enhancing collision avoidance screening. Furthermore, SpaceX recommends Customers consider adopting and following the best practices outlined in the NASA Spacecraft Conjunction Assessment and Collision Avoidance Best Practices Handbook, which can be found at [https://nodis3.gsfc.nasa.gov/OCE\\_docs/OCE\\_50.pdf](https://nodis3.gsfc.nasa.gov/OCE_docs/OCE_50.pdf).

### **6.6 SPACEX RESPONSIBILITIES**

SpaceX responsibilities include the following items. The Parties understand that any material failure by SpaceX to meet its responsibilities may result in changes in the scheduling of the Launch Period or Launch Date; such changes are not subject to any Customer rebooking fees.

#### **6.6.1 LAUNCH SCHEDULING**

SpaceX will advise the Customer approximately sixty days prior to the start of the Launch Period, of the Launch Date. The above-referenced dates will be determined by SpaceX in its sole discretion.

**6.6.2 TRANSPORTATION SERVICES**

- SpaceX will provide transportation of the Payload and associated GSE between facilities at the Launch Site. This includes transportation of the Payload from the PPF to the Launch Complex and transportation of hazardous fluids and gasses between facilities at the Launch Site.
- SpaceX will provide Launch Range coordination for Payload and associated GSE transportation activities when at the Launch Site.
- To the extent required by the Launch Range, SpaceX will arrange safety and security escorts for Payload and GSE transportation events at the Launch Site.
- SpaceX will provide transportation for Customer's non-U.S. personnel between a designated off-site parking area and SpaceX Launch Site facilities, and between SpaceX facilities, on a reasonable schedule. U.S. government regulations require that non-U.S. personnel and U.S. personnel representing non-U.S. entities must be escorted while on a U.S. government Launch Site.

**6.6.3 PAYLOAD INTEGRATION AND ASSOCIATED HARDWARE**

- SpaceX will lead the operations required to physically integrate the Payload with the Launch Vehicle, including any operations involving integrated Payload and Launch Vehicle hardware.
- SpaceX will provide all non-Payload-unique encapsulation equipment, the GSE required to handle the encapsulated Payload, and the GSE required to transport the encapsulated Payload to the Launch Complex.
- SpaceX will provide the equipment to integrate the encapsulated Payload with the Launch Vehicle at the Launch Complex.

**6.6.4 PHOTOGRAPHIC SERVICES**

At SpaceX's sole discretion, SpaceX may provide still photography and/or videography services during selected Payload processing, testing and integration operations. This service does not include delivery or broadcast of photography or videography in real-time or near real-time.

All media intended for release is subject to Launch Range security procedures, U.S. export control laws, and where applicable, the prior written approval of the U.S. Government. Media that includes images of SpaceX hardware or facilities is also subject to SpaceX's prior written approval for release.

**6.6.5 SECURITY**

SpaceX provides security via a combination of locked facilities (security card access or cipher locks), closed circuit video monitoring and/or personnel present 24 hours/day at the relevant Launch Site facilities when Customer flight hardware is present. During any hazardous operations for which the Launch Range safety authority requires non-essential personnel to evacuate, video monitoring will be the sole method of surveillance available. Customer will not be granted access to SpaceX's video footage.

**6.6.6 LAUNCH CAMPAIGN**

SpaceX will prepare for and perform a Launch of the Payload. Starting upon Payload arrival at the Launch Site and throughout the Launch Campaign, the SpaceX mission manager will provide to the Customer, at least once per working day, an updated Launch Campaign schedule (including key milestones and joint operations), relevant Launch Range safety status and information, and Launch Vehicle integration status.

SpaceX may conduct one or more Launch Vehicle wet dress rehearsals (inclusive of loading the Launch Vehicle with propellant) and static fire tests (inclusive of first-stage engine ignition) at the Launch pad prior to Launch. SpaceX may perform these operations with encapsulated Rideshare Payloads mated to the Launch Vehicle.

**6.6.7 FACILITY SUPPORT AND OPERATIONS**

SpaceX will integrate the scheduling of Payload processing activities with Launch Vehicle processing activities. SpaceX will maintain and communicate the integrated schedules and procedures. In addition, SpaceX will act as the primary





point of contact between the Launch Range and the Customer and coordinate all Launch Range support, including the following

- a. Launch Range security and badge control
- b. Launch Range scheduling
- c. Launch Range system safety
- d. Meteorology
- e. Communications and timing
- f. Fire protection
- g. Non-hazardous fluids and gases:
  - a. Gaseous helium per MIL-PRF-27407, Grade A (5700 psi max)
  - b. Gaseous nitrogen per MIL-PRF-27401, Grade A (4150 psi max)
  - c. Compressed Air (120 psi max)
  - d. Isopropyl Alcohol (IPA)

SpaceX will maintain PPF management and scheduling responsibilities throughout the Payload processing and encapsulation phase. As facility manager, SpaceX will require some oversight of Payload activities.

SpaceX will provide training for Customer personnel regarding the PPF (cranes, warning lights, etc.) and applicable Launch Range/facility safety and security procedures. Training will be provided in advance of Payload arrival and offloading at the Launch Site.

#### **6.6.8 LICENSING AND REGISTRATION**

SpaceX will provide to Customer commercially reasonable support and information to enable Customer to satisfy the requirements of all applicable regulatory/licensing agencies and associated statutes, including Launch Range safety, the US Departments of State and Commerce, the US FAA, the US FCC and the CSLA.

Each Party will be responsible for obtaining all Licenses to carry out its obligations under the Agreement. For example, SpaceX is responsible for licensing RF emissions entering free-space from SpaceX-provided hardware and the Customer is responsible for licensing RF emissions entering free-space from Customer-provided hardware.

If Customer or any of Customer's Related Third Parties takes any action or fails to take an action that SpaceX reasonably determines requires delaying any application for or amending any License for which SpaceX is responsible to obtain, SpaceX reserves the right to re-book Customer, with applicable rebooking fees.

#### **6.6.9 MISSION INTEGRATION ANALYSES**

SpaceX will conduct the following analyses in support of the Payload if required. All other environments are verified by Customer using requirements found in Section 3.

##### **6.6.9.1 TRAJECTORY**

SpaceX performs a trajectory and performance analysis in order to analyze the following Mission parameters:

- a. The nominal flight timeline, profile (plots of altitude and acceleration. vs. time), and ground track
- b. The free molecular heating environment at fairing jettison
- c. The Earth-Centered-Earth-Fixed (ECEF) Payload separation state vector
- d. Payload and Co-Payload(s) deploy timeline
- e. Orbit injection accuracy

SpaceX analyzes and implements a single Earth-referenced Launch trajectory, a single Earth-referenced ascent attitude profile, and a single Earth-referenced Payload separation attitude, which will be used for all dates and times throughout the Launch Period. SpaceX does not implement multiple trajectories for various dates/times within the Launch Period,



and does not provide sun-referenced or inertially-referenced attitudes during ascent or for Payload separation. Results will be provided by SpaceX.

#### **6.6.9.2 COLLISION AVOIDANCE**

SpaceX performs an analysis to determine the need for a collision avoidance maneuver following separation of Payload and Co-Payload(s). This analysis will characterize the relative separation distance between the second stage and the Payload for one orbit after separation. This analysis will assume that no propulsive activities are executed by the Payload during the period analyzed. SpaceX does not perform additional analyses with respect to collision avoidance of potential debris or other space objects. These results will be provided by SpaceX as part of the trajectory and performance results described in Section 6.6.9.1.

SpaceX coordinates with applicable US regulatory authorities, such as the FAA and the Combined Space Operations Center (CSpOC), to select a Launch Window that results in a sufficiently low risk of collision with another space object during the Mission. In order to facilitate this coordination with the regulatory authorities, SpaceX will utilize the separation velocity imposed on the Payload by the separation system as documented in the Payload ICD and position predicted by the Trajectory analysis. Any Payload propulsive maneuvers or secondary Payload deployments within three (3) hours of Launch must be coordinated with SpaceX for inclusion in CSpOC analysis and will be documented in the Payload ICD.

#### **6.6.9.3 COUPLED LOADS**

SpaceX performs a CLA to verify the predicted dynamic flight loads and responses of the Payload are within the MPE described in Sections 3.3.2 and 3.3.3. If any results are found to exceed the MPE described in Sections 3.3.2 and 3.3.3, SpaceX will provide the CLA results to the Customer for further evaluation.

#### **6.6.9.4 PAYLOAD SEPARATION**

SpaceX may perform a separation analysis for MicroSat-class Payload Constituents deploying from the Launch Vehicle to verify the Customer provided analysis as described in Section 2.3. CubeSat deployments from Containerized deployers are not specifically analyzed; SpaceX instead relies on the separation properties provided by the Customer. These results are used as an input for the collision avoidance analysis. Since Payload mass properties and slosh are outside of SpaceX's control, SpaceX will evaluate requirements compliance via the ideal analysis case. If required, SpaceX will provide a presentation summarizing the results of the analysis and highlighting any issues or concerns for the Payload.

#### **6.6.9.5 PAYLOAD CLEARANCE**

SpaceX performs a clearance analysis to validate the dynamic envelope compatibility between the Launch Vehicle and the Payload, and the Co-Payload(s) to the Payload, during all phases of the Mission. Clearance analysis results will be provided to the Customer for any Payload in excess of the allowable Payload allowable volume defined in Appendix A.



## 7 OPERATIONS

Launch Vehicle operations are described in this section for launches from CCSFS, KSC, and VAFB. SpaceX launch operations are designed for rapid response (targeting less than one hour from vehicle rollout from the hangar to launch). Customers are strongly encouraged to develop launch readiness capabilities and timelines consistent with a rapid prelaunch concept of operations.

### 7.1 OVERVIEW AND SCHEDULE

The Launch Vehicle system and associated operations have been designed for minimal complexity and minimal time at the pad. Customer Payload processing is performed in the PPF. After completion of standalone Payload operations (over a 7-day period), SpaceX performs the Payload mate to Launch Vehicle hardware followed by fairing encapsulation at the PPF. Payload and Co-Payload arrivals will be scheduled by SpaceX and may be staggered. The encapsulated assembly is then transported to the integration hangar. The Launch Vehicle is processed in the integration hangar at the Launch Complex and then loaded on the TE. The encapsulated assembly is mated to the Launch Vehicle at approximately L-5 days, followed by end-to-end system checkouts. Launch Vehicle systems are designed for rollout and Launch on the same day.

### 7.2 RIDESHARE PAYLOAD DELIVERY AND TRANSPORTATION

Payload and associated GSE must be delivered to the Launch Site by Customer. SpaceX will assist in arranging for Air Force Base access.

### 7.3 RIDESHARE PAYLOAD PROCESSING

SpaceX provides an ISO Class 8 (Class 100,000) PPF for processing Customer Payload, including equipment unloading, unpacking/packing, final assembly, nonhazardous flight preparations, and checkouts. The PPF is available to Customer for two eight-hour working shifts per day. Layouts as well as standard services and equipment available in the PPF for VAFB and CCSFS can be found in the SpaceX Falcon User's Guide, latest revision, available on [www.spacex.com/vehicles/falcon-9/](http://www.spacex.com/vehicles/falcon-9/).

The PPF is also designed to accommodate hazardous operations such as hypergolic propellant loading and ordnance installation. Fueling operations are allowed as an optional service (see Appendix I).

### 7.4 JOINT OPERATIONS AND INTEGRATION

Joint operations begin once Customer has completed the Payload mate to the SpaceX-provided Mechanical Interface, if applicable. Payload to Launch Vehicle hardware mate and fairing encapsulation are performed by SpaceX within the PPF. Fairing encapsulation is performed in the vertical orientation. Transportation is performed in the vertical orientation, and environmental control is provided throughout the transportation activity. Once at the Launch Vehicle integration hangar, the encapsulated assembly is rotated to horizontal and mated with the Launch Vehicle already positioned on the TE.

Once the encapsulated assembly is mated to the Launch Vehicle, the hangar facility HVAC system is connected via a fairing air conditioning duct to maintain environmental control inside the fairing. The Payload and Co-Payload(s) are then reconnected to EGSE (if required) and Customer has a final chance to perform electrical checkouts prior to Launch Vehicle rollout and launch.

### 7.5 LAUNCH OPERATIONS

#### 7.5.1 ORGANIZATION

A breakdown of decision-making roles between SpaceX and the Launch range can be found in SpaceX Falcon User's Guide, latest revision, available on [www.spacex.com/vehicles/falcon-9/](http://www.spacex.com/vehicles/falcon-9/).



### **7.5.2 LAUNCH CONTROL**

Launch countdown monitoring and access to Payload telemetry throughout the Launch countdown is available as an optional service (see Appendix I). Space within the Launch Control Center would be shared between Payload and Co-Payload Customer(s), as documented in a Launch Campaign Plan.

### **7.5.3 ROLLOUT AND PAD OPERATIONS**

After all Payload and Co-Payload(s) EGSE is disconnected and readiness is verified the integrated Launch Vehicle may be rolled out from the hangar to the pad on the TE. Once the Launch Vehicle is at the pad, the fairing air conditioning system is reconnected, which helps maintain environmental control through liftoff. Electrical connectivity is provided via ground cables (reference Section 4.3.6). The Launch Vehicle will typically be erected only once, although the capability exists to easily return it to a horizontal orientation if necessary.

### **7.5.4 COUNTDOWN**

The Launch Vehicle is designed to support a countdown duration as short as one hour. Early in the countdown, the vehicle performs LOX, RP-1 and pressurant loading, and it executes a series of vehicle and range checkouts. The TE strongback is retracted just prior to launch. Automated software sequencers control all critical Launch Vehicle functions during terminal countdown. Final Launch activities include verifying flight termination system status, transferring to internal power, and activating the transmitters. Engine ignition occurs shortly before liftoff, while the Launch Vehicle is held down at the base via hydraulic clamps. The flight computer evaluates engine ignition and full -power performance during the prelaunch hold-down, and if nominal criteria are satisfied, the hydraulic release system is activated at T-0. A safe shutdown is executed should any off-nominal condition be detected.

### **7.5.5 RECYCLE AND SCRUB**

Launch Vehicle systems and operations have been designed to enable recycle operations when appropriate. Although every recycle event and launch window requirement is unique, the Launch Vehicle offers the general capability to perform multiple recycles within a given launch window, eliminating unnecessary launch delays.

In the event of a launch scrub, the TE and Launch Vehicle will stay vertical. However, for any long-duration Launch postponements, SpaceX will return the Launch Vehicle on the TE to the hangar.

## **7.6 FLIGHT OPERATIONS**

A summary of Launch Vehicle flight operations including Liftoff, Ascent, and Payload Separation can be found in SpaceX Falcon User's Guide, latest revision, available on [www.spacex.com/vehicles/falcon-9/](http://www.spacex.com/vehicles/falcon-9/). SpaceX will provide a quick-look orbit injection report to the Customer shortly after Payload separation, including a best-estimate Payload separation state vector as described in Appendix E. Customer is responsible for tracking and contacting the Payload after separation from the Launch Vehicle.



## **8 SAFETY**

### **8.1 SAFETY REQUIREMENTS**

Customers are required to meet AFSPCMAN 91-710 Range User's Manual in the design and operation of their flight and ground systems. These requirements encompass mechanical design, electrical design, fluid and pressurant systems, lifting and handling systems, ordnance and RF systems, GSE, and other design and operational features. SpaceX will serve as the safety liaison between the Customer and the range and will provide templates for document compliance.

### **8.2 HAZARDOUS SYSTEMS AND OPERATIONS**

Most ranges consider hazardous systems and operations to include ordnance operations, pressurized systems that operate below a 4-to-1 safety factor, lifting operations, operations or systems that include toxic or hazardous materials, high-power RF systems and laser systems, batteries, and a variety of other systems and operations. The details of the system design and its operation will determine whether the system or related operations are considered hazardous. Typically, additional precautions are required for operating systems that are considered hazardous, such as redundant valving between pressurant and propellant. Additional precautions will be determined during the safety approval process with SpaceX and the Launch Range. All hazardous operations require procedures that are approved by both SpaceX and the Launch Range prior to execution. Ordnance operations, in particular, require coordination to provide reduced RF environments, cleared areas, safety support and other requirements.

### **8.3 WAIVERS**

For systems or operations that do not meet safety requirements but are believed to be acceptable for ground operations and launch, a waiver is typically produced for approval by the Launch Range safety authority. Waivers require considerable coordination and are considered a last resort; they should not be considered a standard practice.



### APPENDIX A: MECHANICAL INTERFACES AND VOLUMES

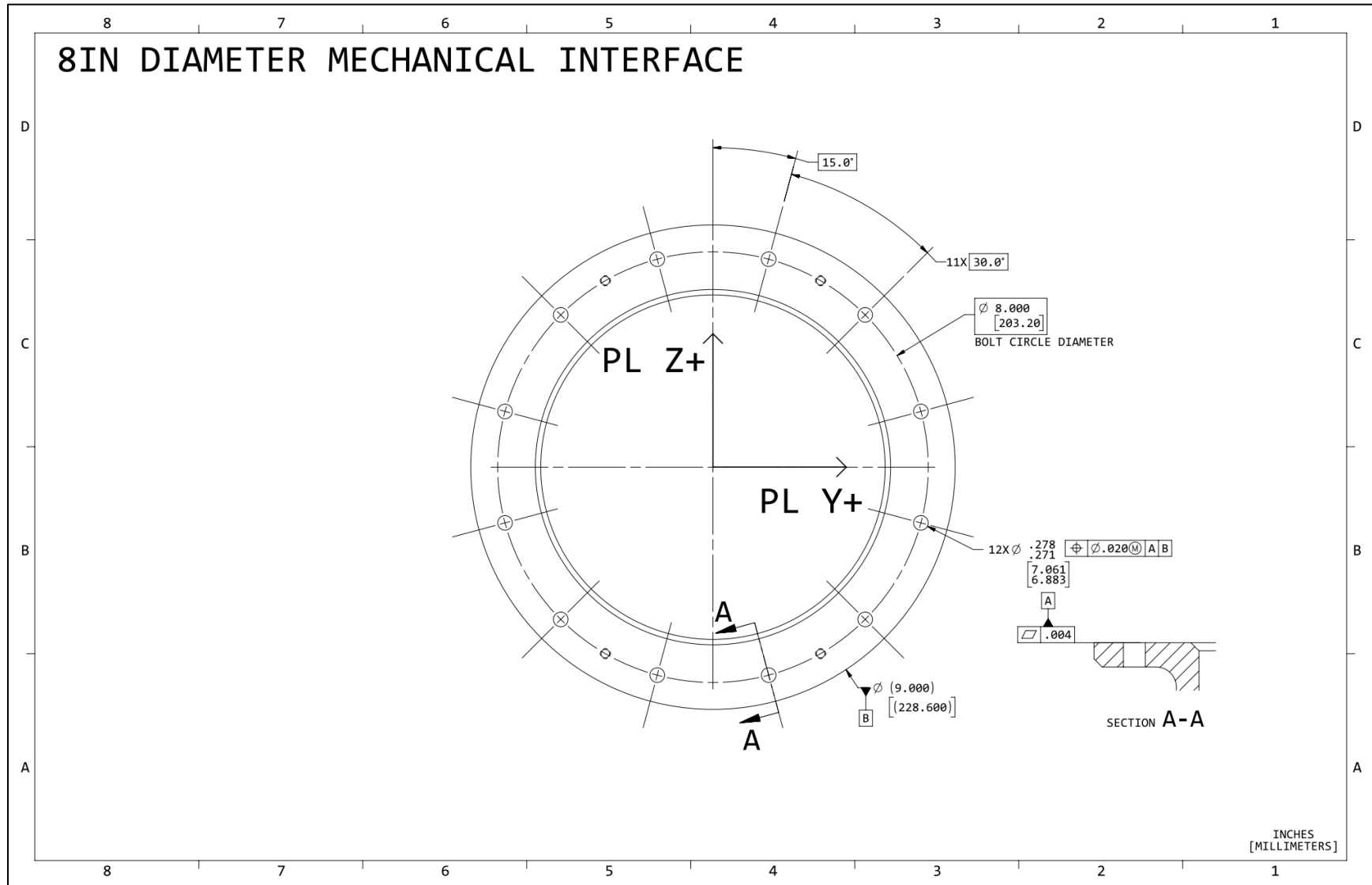


Figure A-1: 8" Diameter Mechanical Interface

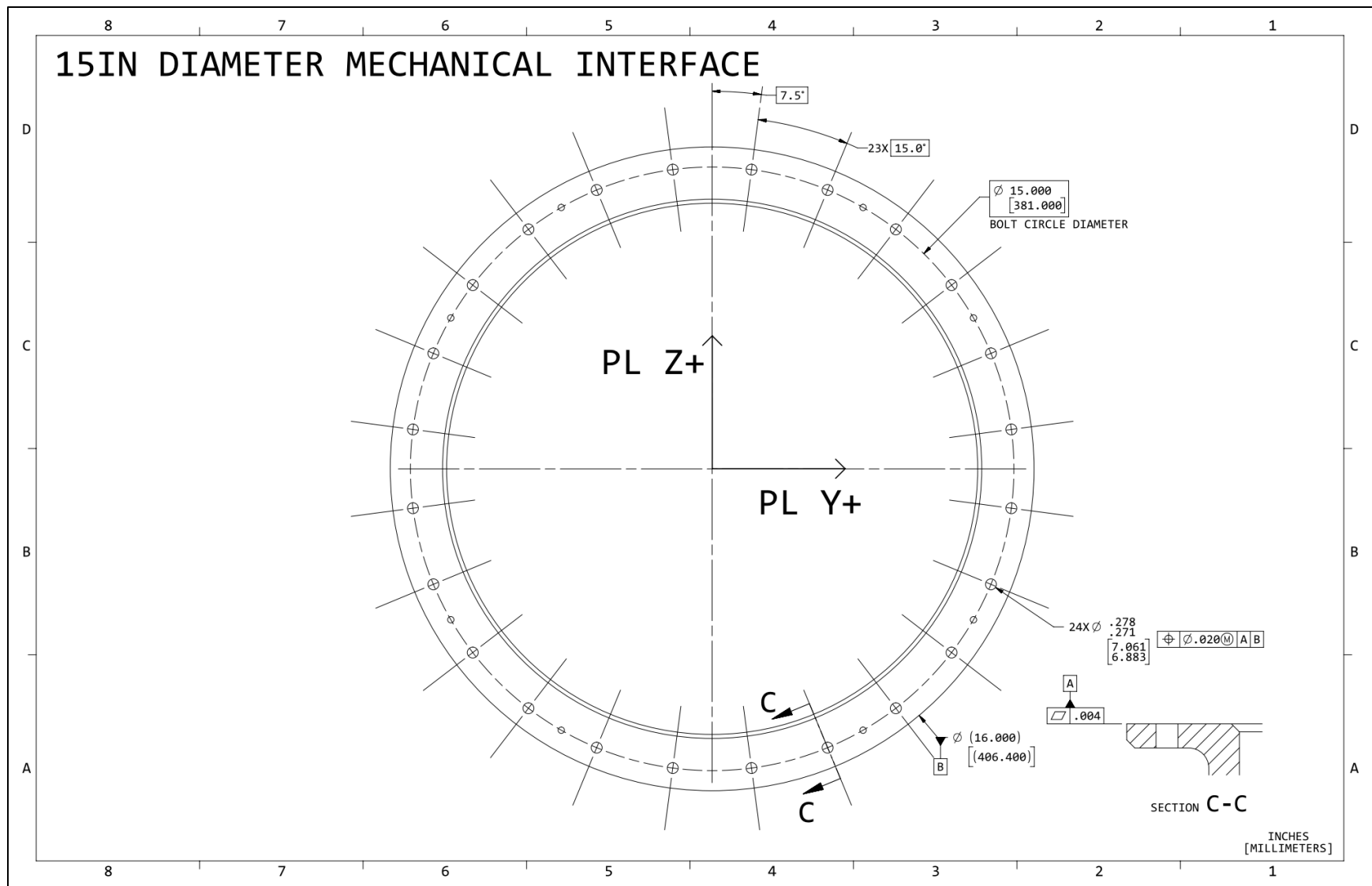


Figure A-2: 15" Diameter Mechanical Interface

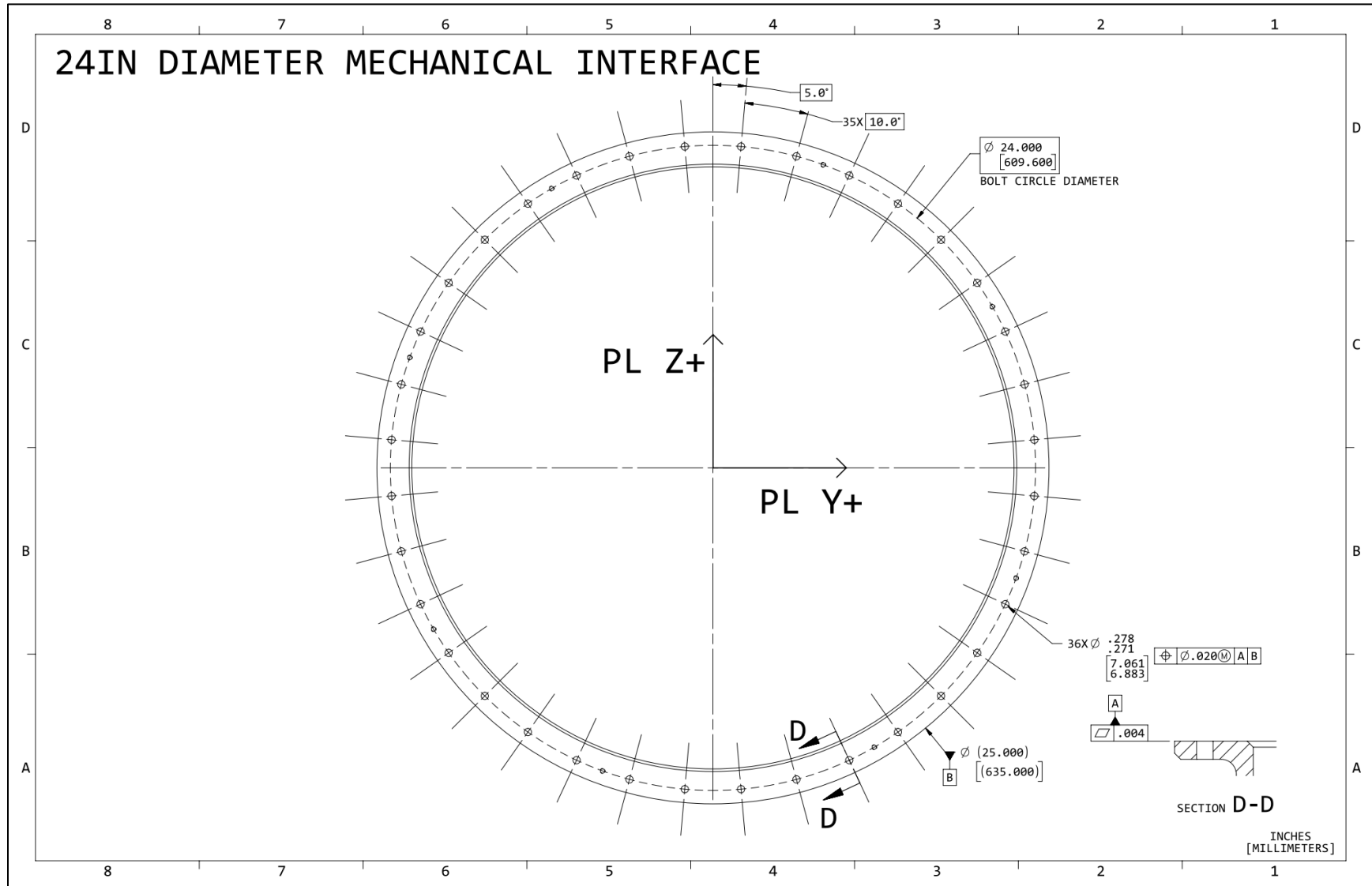


Figure A-3: 24" Diameter Mechanical Interface



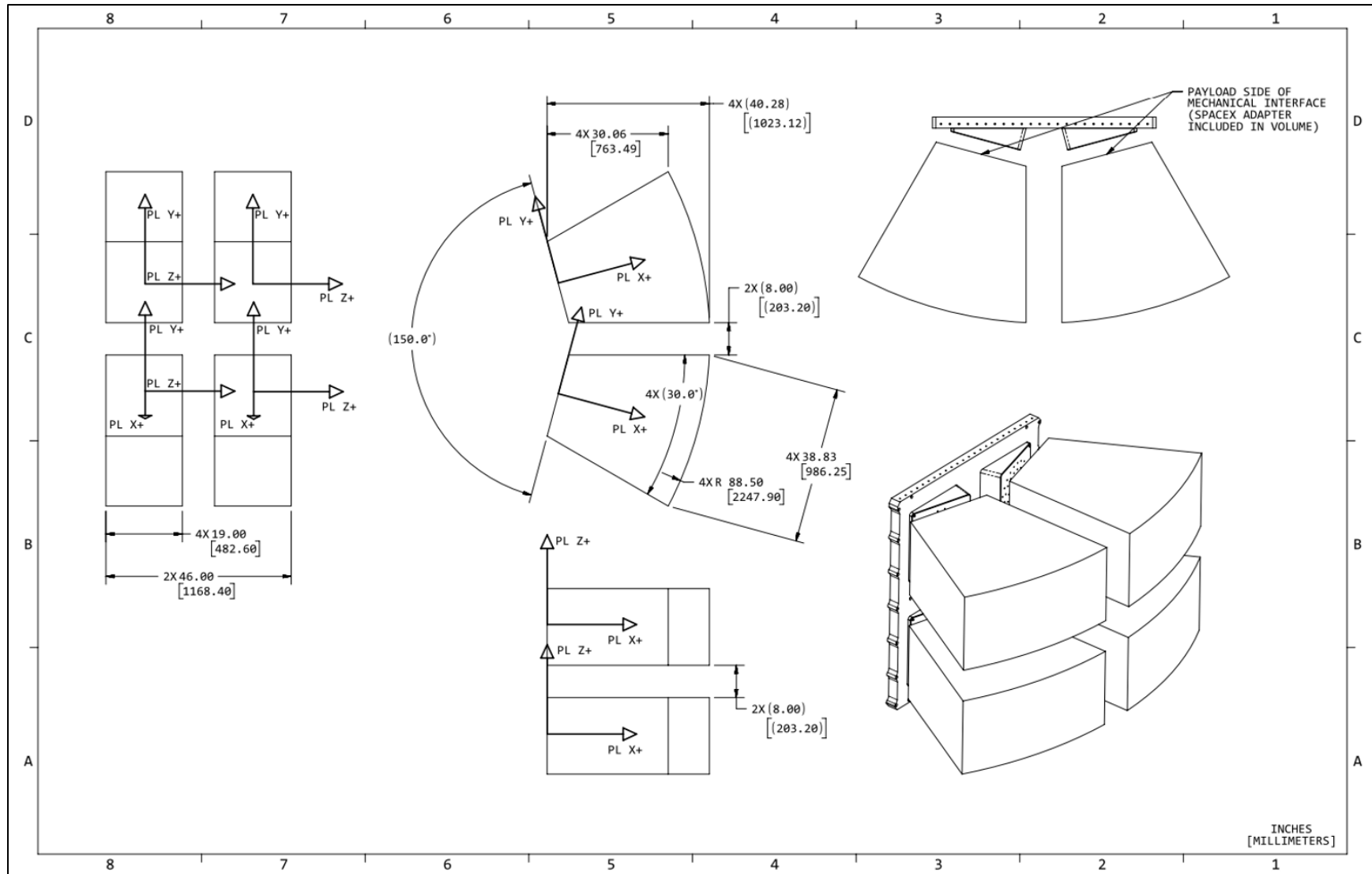


Figure A-4: Rideshare Plate - 1/4 Plate Available Volume

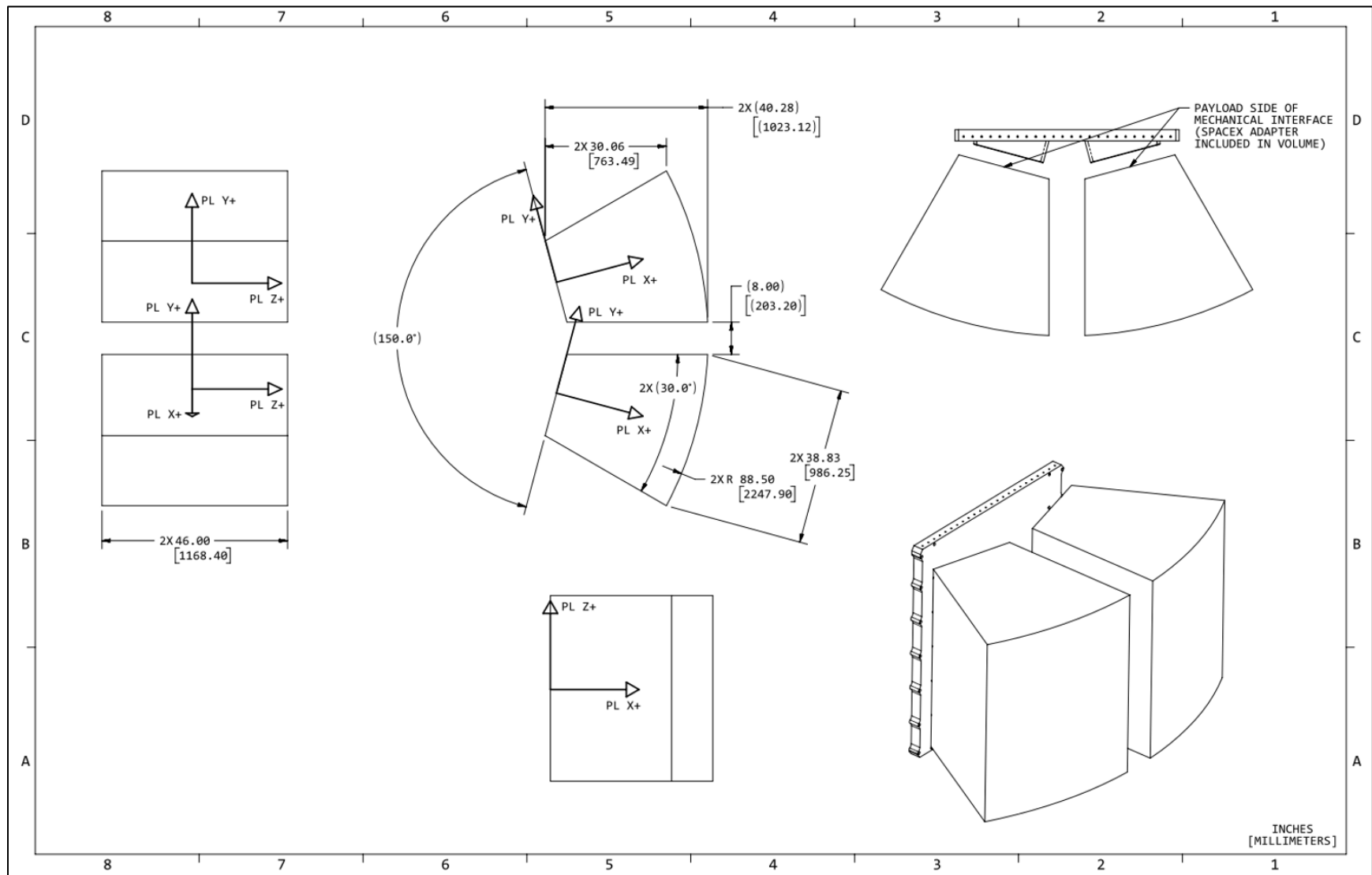


Figure A-5: Rideshare Plate - 1/2 Plate Available Volume

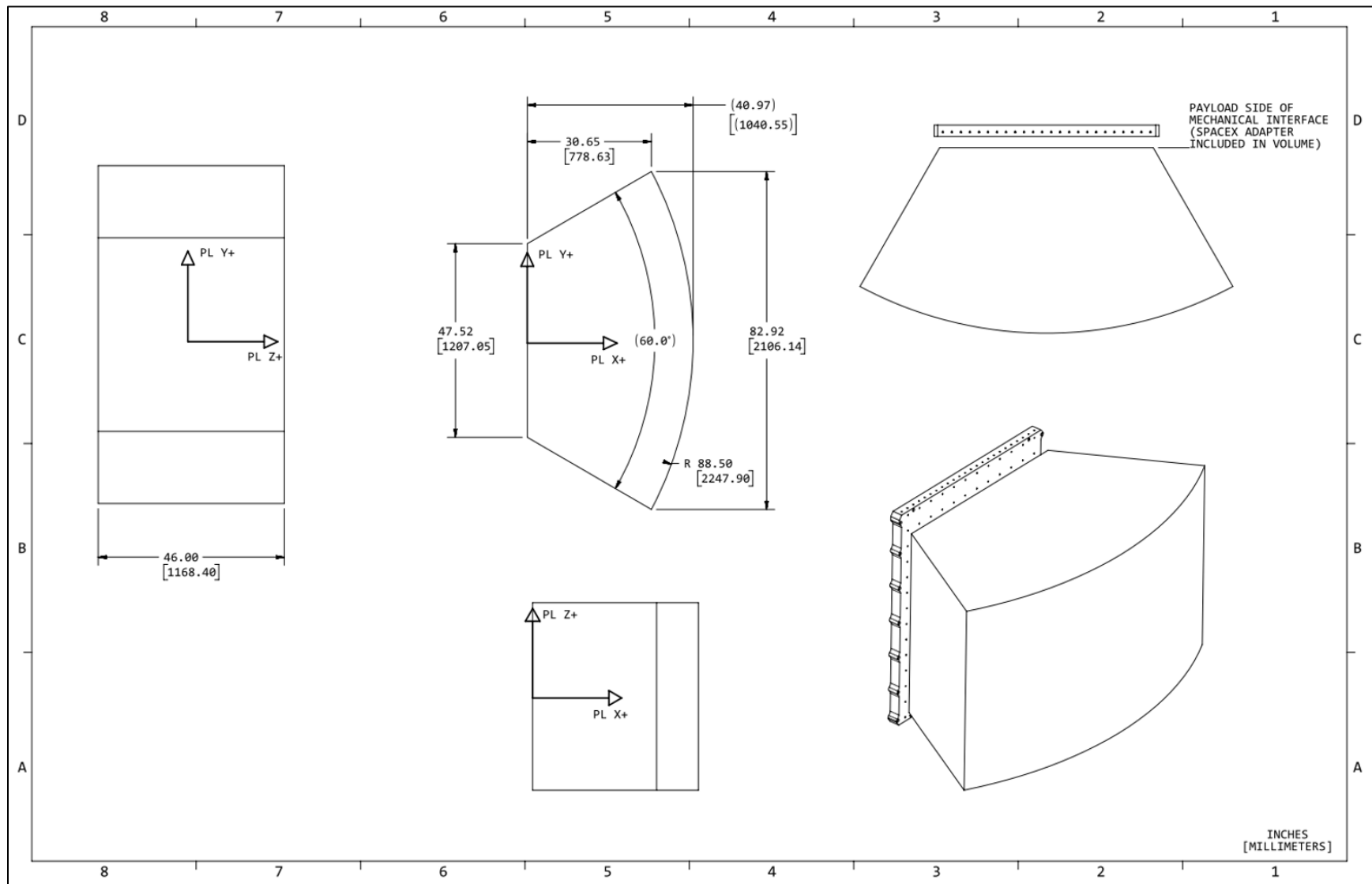


Figure A-6: Rideshare Plate - Full Plate Available Volume

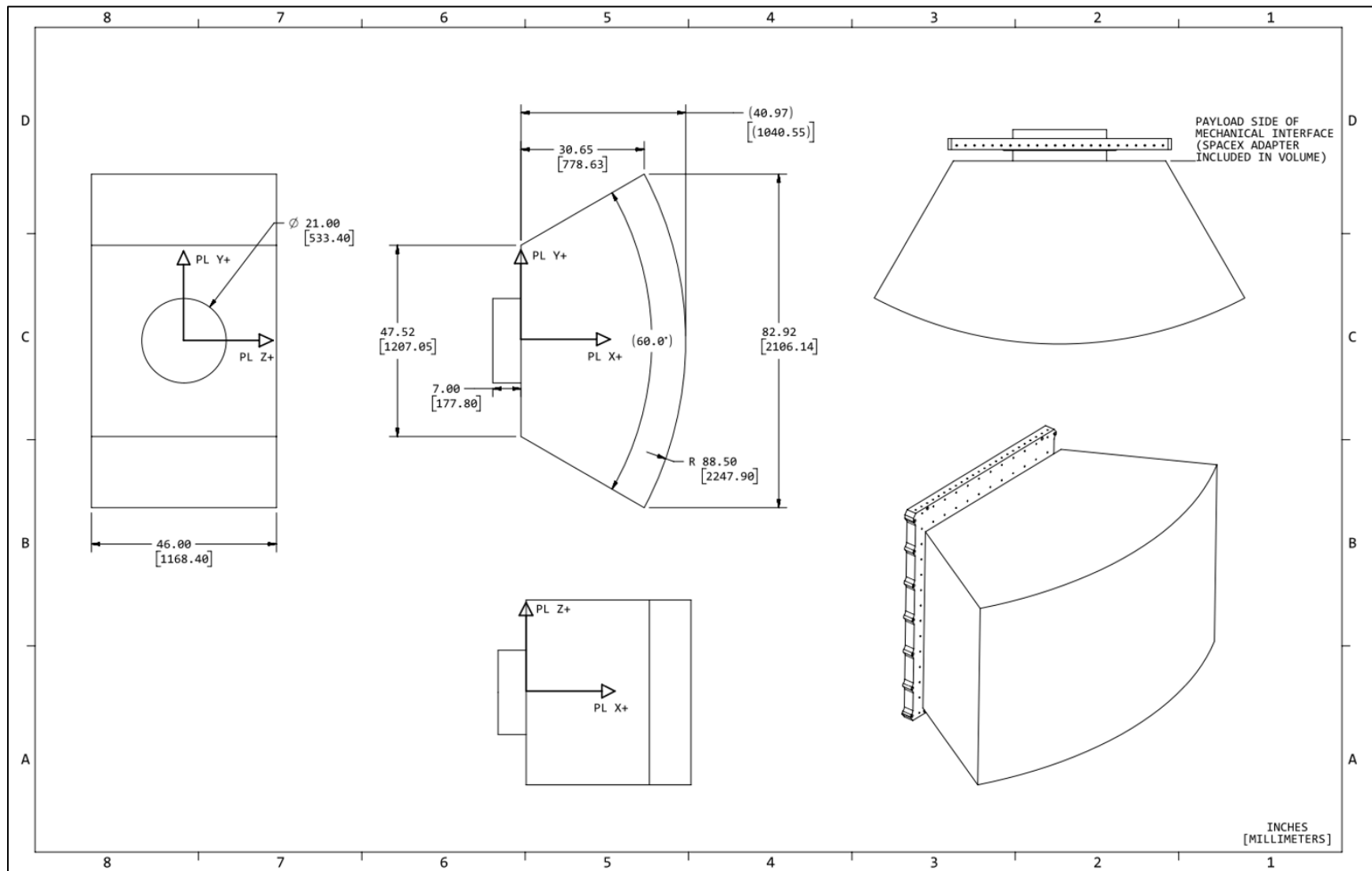


Figure A-7: Rideshare Plate - Full Plate including Internal Available Volume

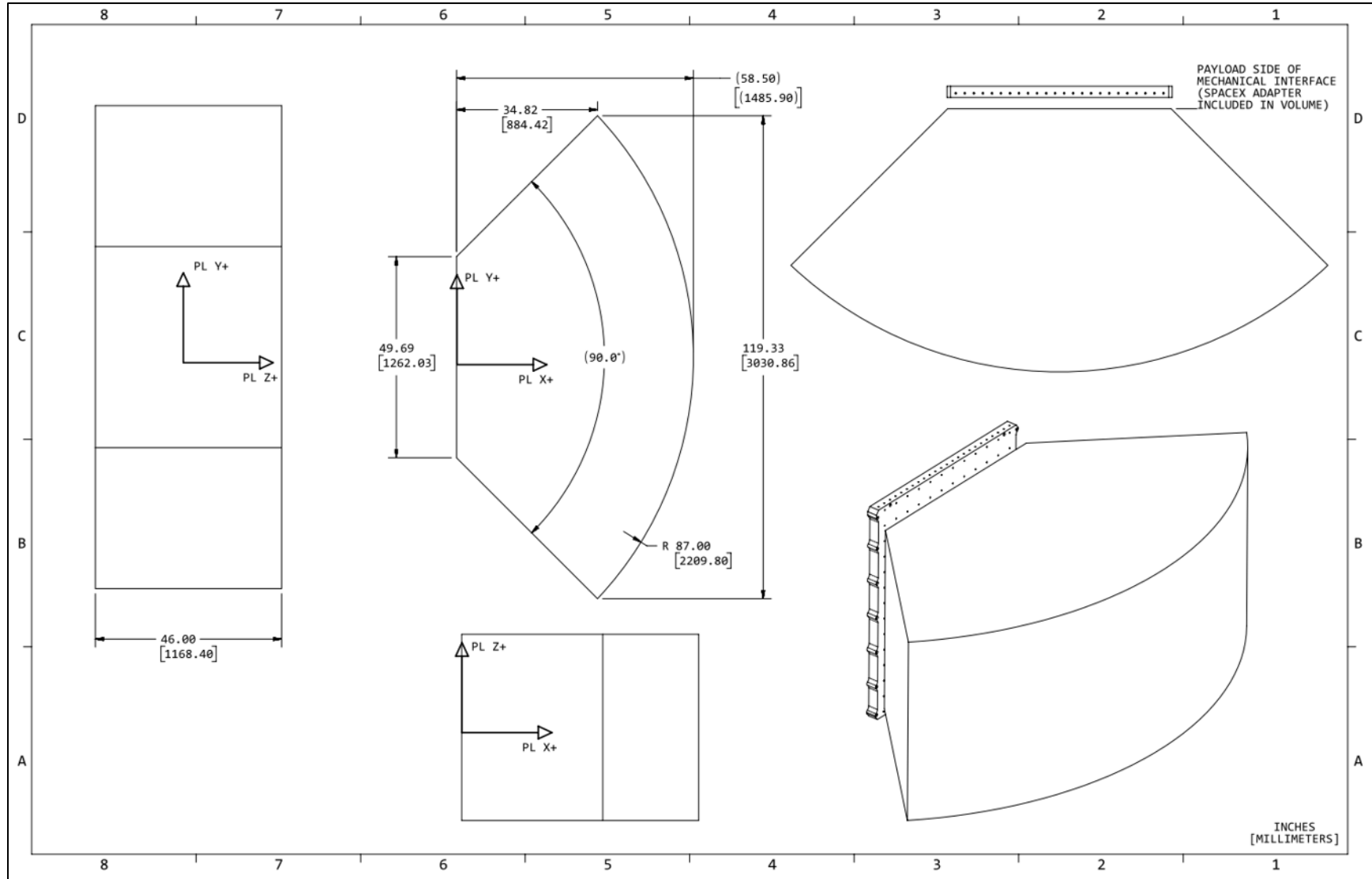


Figure A-8: Rideshare Plate - Full Plate (XL Volume) Available Volume

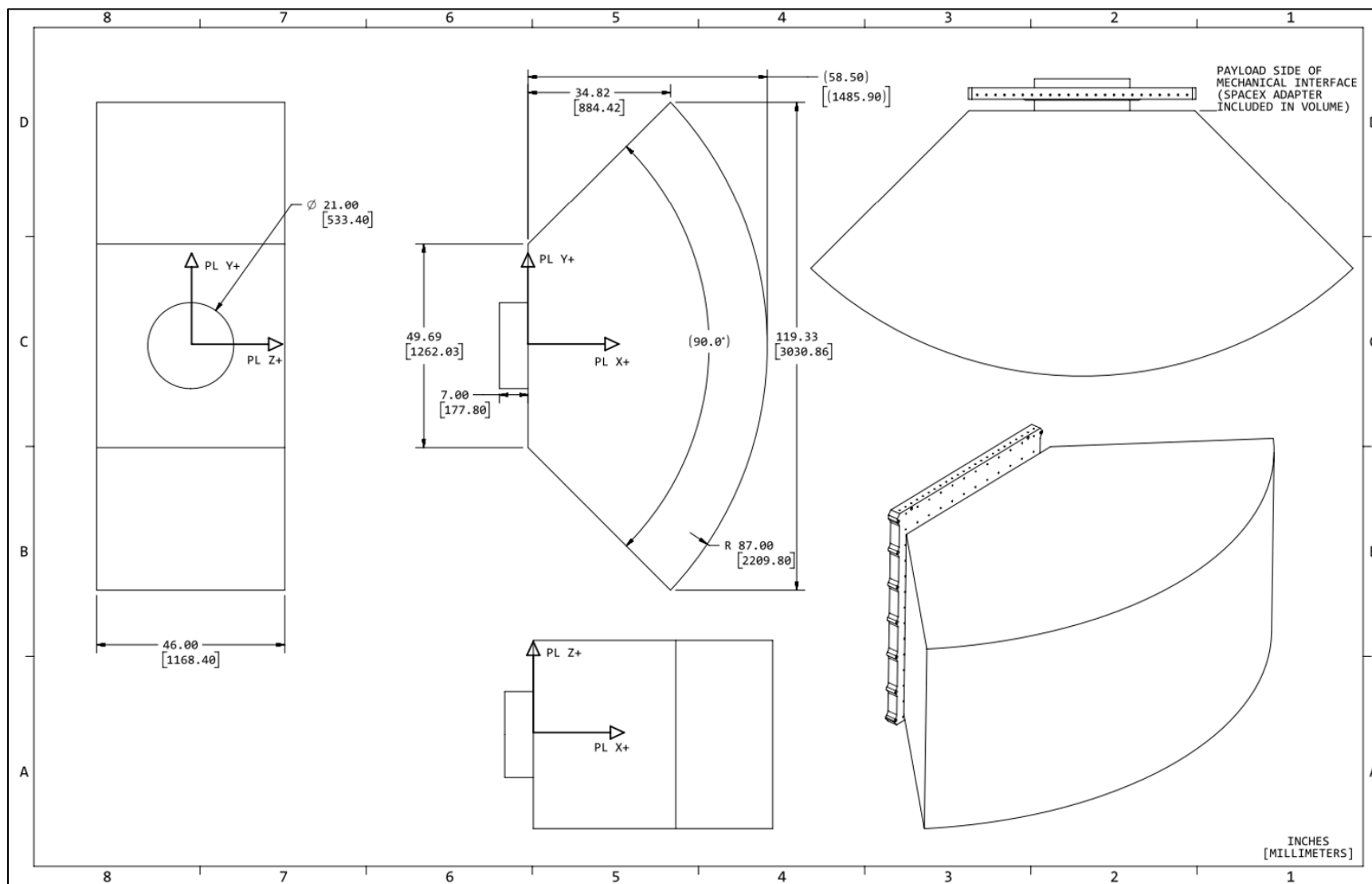


Figure A-9: Rideshare Plate - Full Plate (XL Volume) including Internal Available Volume

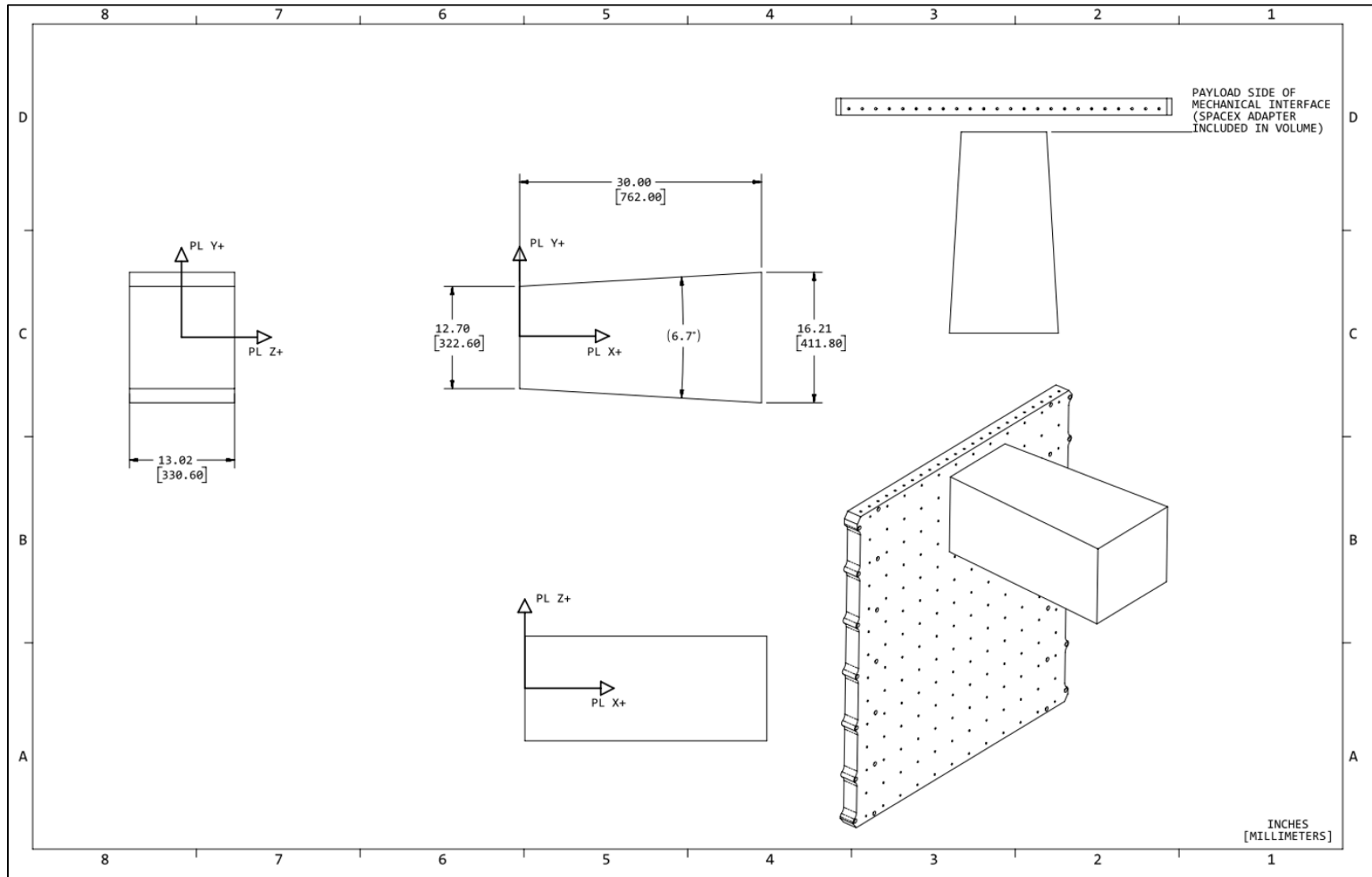


Figure A-10: Rideshare Plate - CubeSat Dispenser Available Volume

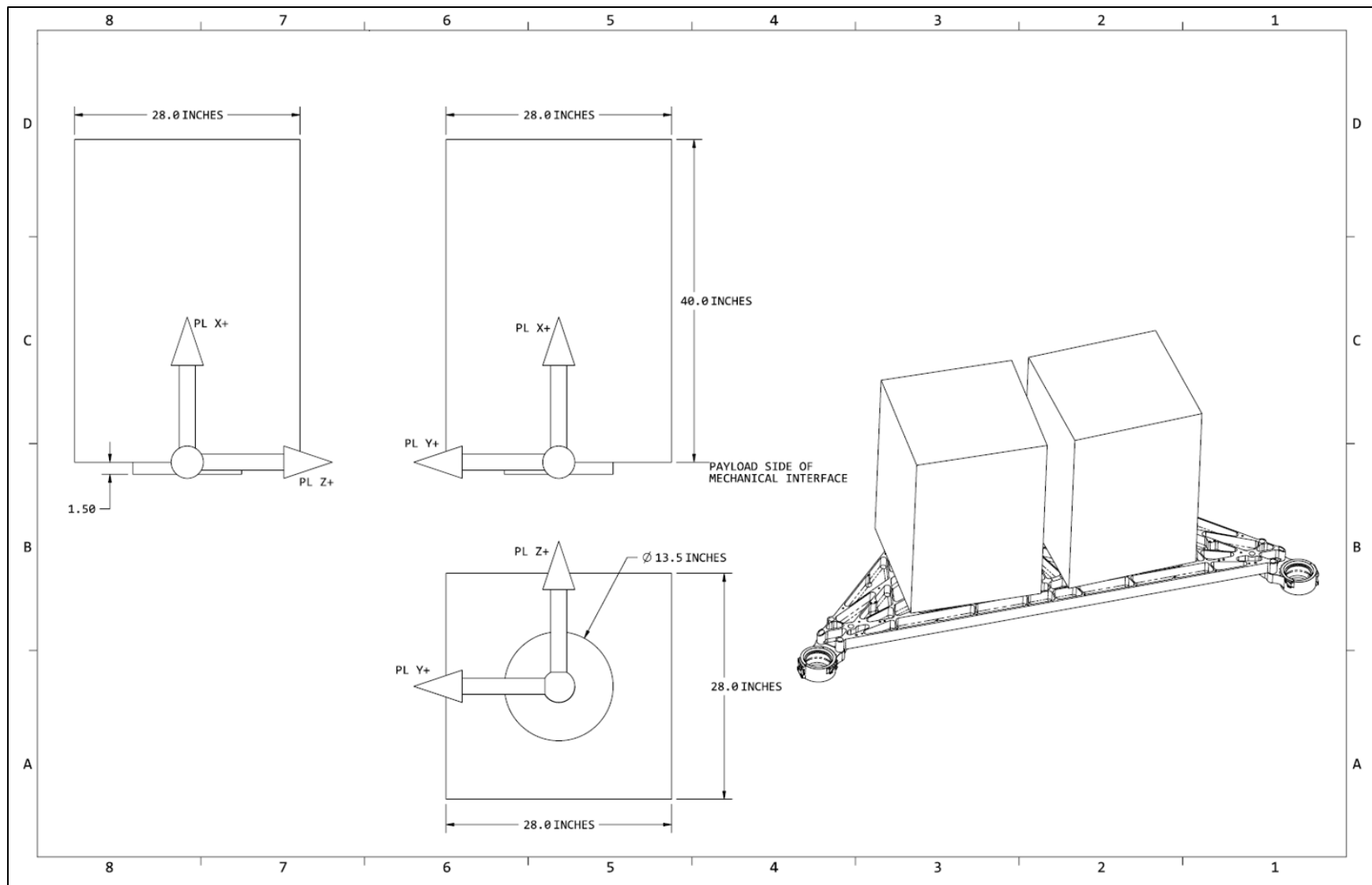
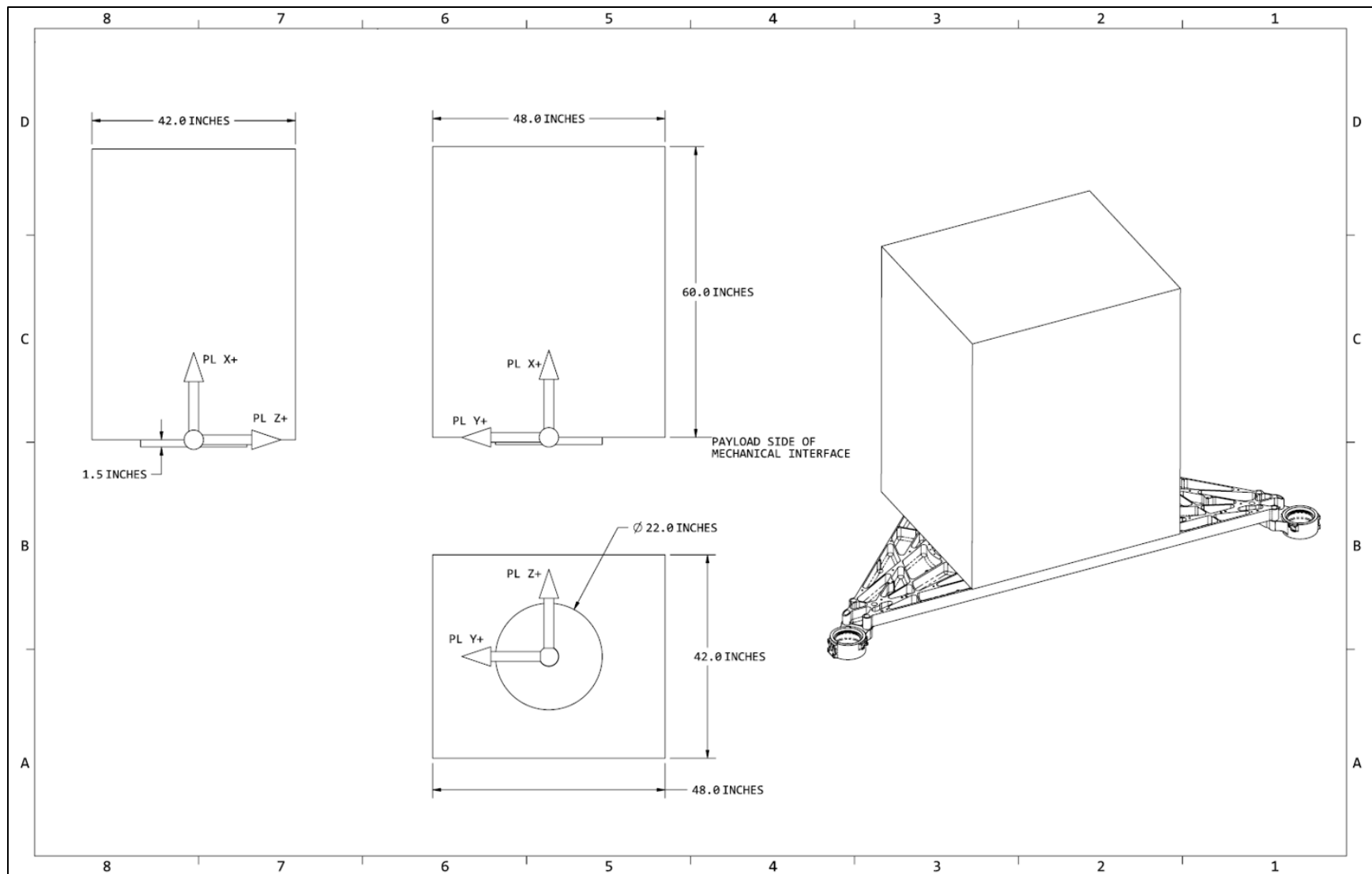


Figure A-11: Starlink Adapter - 15" Diameter Mechanical Interface Available Volume







## APPENDIX B: PAYLOAD DYNAMIC MODEL REQUIREMENTS

An analysis may be run to generate predictions of loads. The environments discussed in Sections 3.3.2 and 3.3.3 are intended to be enveloping for Payloads, thus no delivery of Payload results is guaranteed, but may be provided in the interest of Mission assurance. The Payload dynamic model must be provided to SpaceX as a single-point interface, Craig-Bampton reduced model.

### Payload Craig-Bampton Model Definition

#### Model Requirements:

- The units of the model must be clearly defined (English or SI)
- The model must be a single point interface modal model (see Interface Requirements)
- The Payload coordinate system must follow the coordinate system described in Section 4.2.3
- The model must be Craig-Bampton formatted
- Modal damping must be specified (see Damping Definition section)
- Any uncertainty factor applied to the modal responses must be defined (see Uncertainty Factor section)
- The model must have frequency content up to 150 Hz
- All output requests must be clearly defined (see Analysis Outputs section)
- The model must be an accurate, in good faith, representation of the Payload including primary and secondary structures

#### Interface Requirements:

- The single-interface node to the Launch Vehicle must remain physical with six degrees of freedom
- The Payload coordinate system described in Section 4.2.3 must be used for the boundary interface node output degrees of freedom
- Separation systems, including Lightband-style interfaces, must be included in the Payload model Craig-Bampton reduction with a single-interface node to the Launch Vehicle remaining physical with six degrees of freedom

#### Matrix Requirements:

- The model must be delivered in a NASTRAN, Formatted .op4 file and must include the stiffness and mass matrices as the first two matrices (example NASTRAN deck assign statement below)

```
ASSIGN OUTPUT4='Payload.op4',
UNIT=501,FORMATTED,DELETE
```

#### Example NASTRAN statement for providing matrices

- If the Payload has structures sensitive below 100Hz, the model may include Output Transformation Matrices (OTMs) to recover response of these items
- The mass and stiffness matrices (M and K, respectively) must be provided as complete matrices
- The M and K matrices must be defined as shown below.
  - $i$  are the modal degrees of freedom
  - $b$  are the boundary degrees of freedom
  - $\omega_i^2$  is a diagonal matrix of the eigenvalues
  - $K_{bb}$  is the stiffness from the boundary degrees of freedom

$$M = \begin{bmatrix} M_{bb} & M_{bi} \\ M_{ib} & I \end{bmatrix}, K = \begin{bmatrix} K_{bb} & 0 \\ 0 & \omega_i^2 \end{bmatrix}$$

- OTM a.k.a. Data recovery matrices (*DRM*) used to recover Payload responses (*R*) must be in one of the three forms shown below, where  $\ddot{x}$  are accelerations and  $x$  are displacements.



$$\{R\} = [DRM1] \begin{Bmatrix} \ddot{x}_b \\ \ddot{x}_i \end{Bmatrix}$$

$$\{R\} = [DRM2] \begin{Bmatrix} x_b \\ x_i \end{Bmatrix}$$

$$\{R\} = [DRM1] \begin{Bmatrix} \ddot{x}_b \\ \ddot{x}_i \end{Bmatrix} + [DRM2] \begin{Bmatrix} x_b \\ x_i \end{Bmatrix}$$

- Responses may be recovered using a *DRM1* (acceleration transformation matrix), a *DRM2* (displacement transformation matrix), or using both a *DRM1* and a *DRM2*.
- *DRM1* and *DRM2* must each be provided as separate matrices.
- Load transformation matrices for element forces, pressures, stresses, etc. must be recovered with either a *DRM1* (single or multiple point interface models), or using both a *DRM1* and a *DRM2* (multiple point interface models only).
- Total number of recoveries will be limited to 100 rows.
- Definition of the Craig-Bampton model rows and columns must be provided to facilitate coupling of the Payload to Launch Vehicle model.
- Labels for the rows of the (*DRM*) must be provided for inclusion in results tables.
- All LTM matrices must be defined such that they produce loads when multiplied by accelerations (not in g's) and displacements: e.g. inch/sec<sup>2</sup> and rad/sec<sup>2</sup> and inch and radian or other consistent units.

### Analysis Outputs

No delivery of Payload results is guaranteed, but may be provided in the interest of Mission assurance. If provided, the following CLA outputs are delivered in Microsoft Excel and are reported by load case unless otherwise specified:

- Payload Net-CG response max/min table
- OTM response max/min tables\*
- Interface sine vibe curves with Q specified by Customer

\* OTM = Output Transformation Matrix. May also be referred to as a DRM (Data Recovery Matrix). OTMs can include DTM (Displacement Transformation Matrix), ATM (Acceleration Transformation Matrix), LTM (Load Transformation Matrix) and others.

The output coordinate system of the net-CG max/min tables and the interface sine-vibe curves will be defined in the coordinate system of the Payload, as described in Section 4.2.3.

If outputs in any other coordinate system are desired, then the Customer must generate and provide such outputs in the ATM and/or LTM response recovery matrices.

### Damping Definition

Diagonal modal damping must be defined as a percent of critical (and may vary from mode to mode). Damping values should be test-correlated where possible.



## Uncertainty Factor

SpaceX, as a standard practice, will apply a model uncertainty factor to all responses that reflects launch configuration maturity. However, if Customer desires the application of a larger model uncertainty factor, this must be specifically requested. Under no circumstance will the model uncertainty factor be less than that used in SpaceX standard practice.

## Documentation

SpaceX requests that the Customer's dynamic model be accompanied by documentation that includes:

1. Definition of units used (SI or English)
2. Location of all interface grids in Payload coordinate system
3. Comparison of unreduced (FEM) and condensed (Craig-Bampton) models
  - a. Mass
  - b. Center of gravity relative to interface
  - c. Strain energy
  - d. First seven modes of free-free analysis
  - e. Modal analysis, including modal effective mass
4. A list of all frequencies
5. Pictures and/or descriptions and frequencies of the first few mode shapes (including the three fundamental modes in X, Y, and Z)
6. Definition of damping
7. Definition of the model response (dynamic) uncertainty factor
8. (Optional) If internal Payload responses are requested, provide appropriate DRMs (ATMs, DTMs, and LTM) as well as tables defining the rows of these matrices.
9. (Optional) Definition of any Payload limit loads, including primary structure and component level, in order for SpaceX to evaluate the CLA results (net CG, interface loads, and ATM/DTM/LTM) and determine if the CLA indicates an exceedance of Payload structural capability.

The above list is not all-inclusive, and Customer is encouraged to provide additional information that will assist SpaceX in processing the Payload dynamic model for the coupled loads analysis.



## APPENDIX C: PAYLOAD CAD MODEL REQUIREMENTS

Customer must provide SpaceX a CAD model of the Payload in NX parasolid, or STEP 214 or lower file format. SpaceX will integrate the Payload CAD model with the models of the Launch Vehicle second stage, SpaceX-provided Mechanical Interface, and fairing for visualization, integration, clearance check, and operations development purposes.

SpaceX uses Siemens NX for CAD processing and, upon mutual agreement of the Parties, can accept Customer CAD models in a Parasolid file, the native format of NX.

The Payload CAD model must be simplified by the Customer and focus primarily on outer mold line and interface fidelity (to facilitate efficient model manipulation and processing). Customer must limit their CAD model complexity, as requested by SpaceX, to only the details and interfaces necessary for integration with the Launch Vehicle, while retaining the basic structure of the Payload. Spurious information must be removed from the model by Customer before transmission to SpaceX (an example of unnecessary detail is thousands of bodies within a CAD model representing individual cells on a solar array).

Mass properties are provided in concert with CAD. This mass data must match exactly with the delivered CAD coordinate system configuration and units.

The Payload CAD model must include the following information in order for SpaceX to analyze clearances, prepare compatibility drawings, and produce Payload ICD images:

- Payload interface to Launch Vehicle:
  - Payload mechanical interface to Launch Vehicle
  - Separation connectors and associated brackets
  - Pusher pads
- Components subject to review for clearance analysis:
  - External components to review for clearance to fairing volume (e.g. solar array panels, aft and forward antenna components, reflectors)
  - Any components in the immediate vicinity (<20 cm) of the interface components above
  - Any components which protrude below the separation plane
- Any points which may require access after encapsulation
- Simple Payload bus structure.

The Payload CAD model must not include:

- Internal Payload or bus components
- Spurious details, including individual solar array cells, fasteners, antenna, reflectors, etc., that do not add to the understanding of external volumes.

Prior to delivering CAD to SpaceX, please verify:

- All SpaceX hardware has been removed
- Entire payload is fully contained within the desired flight configuration keep-in volume
- Simplified bodies fully envelope OML of actual payload
- All direct LV interface bodies are included
- File size is 50Mb or less
- Payload is properly configured: origin is at SpaceX standard interface, clocked correctly, and agrees with corresponding mass properties



## APPENDIX D: PAYLOAD ENCAPSULATION & LAUNCH READINESS CERTIFICATES

The Payload Customer must provide Payload readiness certification letters prior to Payload encapsulation and prior to Launch Vehicle roll out to the Launch Pad. The letter templates below are broken out into three possible scenarios:

- Scenario A: No battery charging after stand-alone operations
- Scenario B: Battery charging prior to Launch Vehicle rollout to Launch Pad (Optional Service)
- Scenario C: Battery charging at Launch Pad (Optional Service)

### ENCAPSULATION READINESS LETTER TEMPLATE

[Insert Company Logo]

[Insert Company Name]  
[Insert Company Address]

**To:** Space Exploration Technologies Corp. (SpaceX)  
**From:** [Insert Company Name]  
**Date:** [Insert Date]  
**Subject:** Encapsulation Readiness Certification Letter

[Insert Company] certifies that the [Insert Name] Rideshare Payload is ready for fairing encapsulation. [Insert Company] confirms the following:

1. All Remove Before Flight (RBF) items have been removed from the Rideshare Payload
2. All Add Before Flight (ABF) items have been installed on the Rideshare Payload
3. All closeout pictures have been taken and reviewed
4. All mechanical and electrical connections between the [Insert Name] Rideshare Payload and the SpaceX Rideshare dispenser hardware is complete
5. No entry into the fairing is required once the Rideshare Payload is encapsulated

#### [CHOOSE ONE OF THE FOLLOWING]

- A. [Insert Company] certifies that the [Insert Name] Rideshare Payload batteries were last charged to full capacity on [Insert Date] at [Insert Time] [Insert Local Time Zone] and will remain flight ready for up to 45 days after Payload encapsulation [Insert encapsulation + 45 days Date].
- B. [Insert Company] certifies that the [Insert Name] Rideshare Payload batteries will be fully charged prior to Launch Vehicle roll out to the Launch Pad and remain flight ready for up to 5 days since last charge.
- C. [Insert Company] certifies that the [Insert Name] Rideshare Payload batteries will be fully charged while connected to the Launch Pad and that charging will be terminated prior to T-1 hour.

Sincerely,

[Insert Signature]

[Insert Company]

**LAUNCH READINESS LETTER TEMPLATE**

[Insert Company Logo]

[Insert Company Name]  
[Insert Company Address]

**To:** Space Exploration Technologies Corp. (SpaceX)  
**From:** [Insert Company Name]  
**Date:** [Insert Date]  
**Subject:** Launch Readiness Certification Letter

[Insert Company] certifies that the [Insert Name] Rideshare Payload is GO for launch on the Falcon 9 rocket, including conforming to all applicable Payload safety requirements of the Air Force Space Command Range Safety User Requirement Manual (AFSPCMAN 91-710), as tailored for the Mission.

[Insert Company] has reviewed all open issues and risks and certifies that there are no current constraints to Launch. If there are any new issues that arise prior to Launch, [Insert Company] will inform SpaceX.

**[CHOOSE ONE OF THE FOLLOWING]**

- A. As certified in the Encapsulation Readiness Certification Letter dated [Insert Date], the [Insert Name] Rideshare Payload batteries were last charged to full capacity on [Insert Date] at [Insert Time] [Insert Local Time Zone] and will remain flight ready for up to 45 days after Payload encapsulation [Insert encapsulation + 45 days Date].
- B. [Insert Company] certifies that the [Insert Name] Rideshare Payload batteries were last charged on [Insert Date] at [Insert Time] [Insert Local Time Zone] to full capacity and will remain flight ready for up to 5 days since last charge, [Insert last charge + 5 days Date].
- C. [Insert Company] certifies that the [Insert Name] Rideshare Payload batteries will be fully charged while connected to the Pad and that charging will be terminated prior to T-1 hour.

Sincerely,

[Insert Signature]

[Insert Company]



## APPENDIX E: DELIVERY FORMAT OF SEPARATION STATE VECTOR

### PRE-LAUNCH EXAMPLE

SpaceX OPM output (generated YYYY-MM-DD-Day-HH-MM-SS):

All orbital elements are defined as osculating at the instant of the printed state. Orbital elements are computed in an inertial frame realized by inertially freezing the WGS84 ECEF frame at time of current state. This OPM is provided based on flight telemetry from the second-stage, and therefore represents the state of the second-stage and not the state of any other body. Any position, velocity, attitude, or attitude-rate differences between the second-stage and any other body need to be accounted for by the recipient of this OPM.

```
UTC time at liftoff:                DOY:HH:MM:SS.SS
UTC time of current state:          DOY:HH:MM:SS.SS
Mission elapsed time (s):           +XX.XX
ECEF (X,Y,Z) Position (m):          +XXXXXX.XXX, +XXXXXXXX.XXX, +XXXXXXXX.XXX
ECEF (X,Y,Z) Velocity* (m/s):       +XXXX.XXX, +XXXX.XXX, +XXXX.XXX
LVLH to BODY quaternion (S,X,Y,Z): +X.XXXXXXX, +X.XXXXXXX, +X.XXXXXXX, +X.XXXXXXX
Inertial body rates (X,Y,Z) (deg/s): +X.XXXXXXX, +X.XXXXXXX, +X.XXXXXXX
Apogee Altitude** (km):              +XXXXX.XXX
Perigee Altitude** (km):             +XXX.XXX
Inclination (deg):                  +XX.XXX
Argument of Perigee (deg):          +XXX.XXX
Longitude of the Asc. Node*** (deg): +XXX.XXX
True Anomaly (deg):                 +XX.XXX
```

Notes:

- \* ECEF velocity is Earth relative
- \*\* Apogee/Perigee altitude assumes a spherical Earth, 6378.137 km radius
- \*\*\* LAN is defined as the angle between Greenwich Meridian (Earth longitude 0) and the ascending node

### POST-LAUNCH EXAMPLE

```
# SpaceX OPM output for XXX Mission
```

```
# Notes:
```

- # - ECEF velocity is Earth relative
- # - Apogee/Perigee altitude assumes a spherical Earth, 6378.137 km radius
- # - Orbital elements are computed in an inertial frame realized by inertially freezing the WGS84 ECEF frame at time of current state
- # - State is post-deployment, so includes separation delta-velocity

```
header:
```

```
  generation_date: YYYY-MM-DD-Day-HH-MM-SS
  launch_date:   YYYY-MM-DD-Day-HH-MM-SS
```

```
deployments:
```

```
- name: payload-xxx
  sequence_number: 1
  mission_time_s: +XX.XX
  date: YYYY-MM-DD-Day-HH-MM-SS
  r_ecef_m: [+XXXXXX.XXX, +XXXXXX.XXX, +XXXXXX.XXX]
  v_ecef_m_per_s: [+XXXXX.XXX, +XXXXX.XXX, +XXXXX.XXX]
  mean_perigee_altitude_km: +XXX.XXX
  mean_apogee_altitude_km: +XXX.XXX
  mean_inclination_deg: +XX.XXX
  mean_argument_of_perigee_deg: +XXX.XXX
  mean_longitude_ascending_node_deg: +XXX.XXX
  mean_mean_anomaly_deg: +XX.XXX
  ballistic_coef_kg_per_m2: +XX.XX

- name: payload-xxx
  sequence_number: 2
  mission_time_s: +XX.XX
  date: YYYY-MM-DD-Day-HH-MM-SS
  r_ecef_m: [+XXXXXX.XXX, +XXXXXX.XXX, +XXXXXX.XXX]
  v_ecef_m_per_s: [+XXXXX.XXX, +XXXXX.XXX, +XXXXX.XXX]
  mean_perigee_altitude_km: +XXX.XXX
  mean_apogee_altitude_km: +XXX.XXX
  mean_inclination_deg: +XX.XXX
  mean_argument_of_perigee_deg: +XXX.XXX
  mean_longitude_ascending_node_deg: +XXX.XXX
  mean_mean_anomaly_deg: +XX.XXX
  ballistic_coef_kg_per_m2: +XX.XX
```

```
...
```





## APPENDIX F: PAYLOAD LICENSING CERTIFICATION

[Insert Company Logo]

[Insert Company Name]  
[Insert Company Address]

**To:** Space Exploration Technologies Corp. (SpaceX)  
**From:** [Insert Company Name]  
**Date:** [Insert Date]  
**Subject:** [Payload Name] Payload Licensing Certification Letter

[Insert description of Payload]

[Insert Company] certifies that:

- (1) it has obtained all required Payload Licenses, and
- (2) it has reviewed and understood the Hazardous Materials Table found at <https://www.law.cornell.edu/cfr/text/49/172.101> and accurately provided to SpaceX the list of Hazardous materials found within the Payload, and
- (3) all information submitted to SpaceX and/or to licensing agencies regarding its Payload is complete and accurate.

Sincerely,

[Insert Signature]

[Insert Company]



## APPENDIX G: DELIVERABLES DESCRIPTION

The deliverables described in this appendix correspond to SpaceX and Customer deliverables and corresponding due dates defined in Table 1 of the Payload contract's statement of work.

**Table G-1: SpaceX Deliverables Description**

Milestone	SpaceX Deliverables	Description
Contract Signature	TAA questionnaire or Export Compliance Agreement template	Representations and certifications for Customer to complete for TAA application (if not already provided prior to Agreement signature) or Export Compliance Agreement between US parties and SpaceX.
	Payload configuration worksheet	Template for Payload details including top-level Payload information and Payload Constituents (reference Appendix H).
Mission Integration Kickoff	Launch Range introduction	Introduction to the Launch Range and SpaceX Launch site facilities, including security information, badging and access control, and example Rideshare Mission operational overview.
	Payload Range Safety requirements	Summary of Range Safety submissions required for Rideshare Payloads.
	Range Safety submission document templates	Document templates for the Range Safety submission deliverables.
	Launch Site Facility User's Guide	User's Guides covering SpaceX Launch Site facilities for Vandenberg Space Force Base (VSFB) and Cape Canaveral Space Force Station (CCSFS).
	Rideshare ICD template	Template of the ICD containing placeholders for Mission-specific requirements and other interface information to be developed and populated during the course of Mission integration. The ICD defines the Mission requirements and interfaces between Customer and SpaceX systems.
	Dynamic model worksheet	A worksheet for the Customer to complete which serves as a companion document to accompany the Customer Payload dynamics model (reference Appendix B) delivery.
	Mass properties worksheet	A worksheet for the Customer to complete which describes the Payload mass properties, including its center of gravity, moments of inertia and products of inertia for the Payload, broken up into fly-away and stay-behind portions.
	Separation system properties worksheet	A worksheet for the Customer to complete which describes the Payload separation system mechanical properties including spring, switch, and connector locations and separation energy.
	Customer separation analysis template	Template for Customer to summarize Payload separation analysis defined in Section 2.4.
	Payload transmitter verification worksheet	A worksheet for Customer to use to verify Payload transmitter turn on times in accordance with Section 3.3.7.2.
	Electrical interface pinout worksheet	A spreadsheet that describes the Launch Vehicle to Payload electrical harness properties and pin-outs.
	Customer-built harness build guide & verification worksheet	Detailed documentation that describes the requirements for Customer-built harnesses as well as a worksheet for Customer to use in order to verify build requirements.
	Payload environmental test approach worksheet	A worksheet for the Customer to complete which defines the test approach for the Payload including requested deviations to Section 3.4 and test schedule, which must be approved by SpaceX.
Payload environmental verification report template	Template for Customer to summarize final environmental verification test and/or analysis results for fully integrated Payload testing in order to show compliance to Section 3.4 and in accordance with the SpaceX approved Payload environmental test approach.	
Launch Campaign Planning Kickoff	Launch campaign planning checklist template	Launch planning checklist template to track Launch campaign documentation, GSE shipment list, Customer personnel attendance, Payload details related to Launch Site operations, an OPM email distribution list, and Launch campaign action items.
	Launch campaign daily schedule template	Template for daily Launch Site activity planning for Customer to provide details such as stand-alone operations duration, SpaceX resource requirements, and hazardous operations.
	Licensing and insurance information template	A template for Customer to capture SpaceX licensing inputs such as hazardous materials and Customer crosswaivers inputs, as well as Payload insurer details, launch and in-orbit subrogation waiver accounting, and requests for additional parties to be included on SpaceX's third party liability insurance policy.
	Payload and equipment delivery information	General information regarding the process and requirements for delivering the Payload and Customer GSE/EGSE to the Launch Site.
Launch Campaign Planning	Launch campaign planning checklist (preliminary)	Preliminary draft of Launch campaign planning checklist including preliminary customer inputs.
	Launch integration schedule (preliminary)	Schedule of Launch Site operations identifying Payload stand-alone activities and combined Payload/Launch Vehicle operations for the Mission.



Milestone	SpaceX Deliverables	Description
Mission Integration	Launch campaign plan (preliminary)	Plan for Payload integration and Launch, including the facilities to be used, Payload space allocation in those facilities, and the top-level operations to be performed for both Launch Vehicle and Payload processing.
	Predicted orbit injection report	Predicted state vector information, based on a nominal trajectory optimized for the Mission. This state vector will be provided in SpaceX-defined format (reference Appendix E).
	Draft ICD	Preliminary draft of the ICD utilizing inputs from Customer for Mission-specific requirements and other interface information to be developed and populated during the course of Mission integration. The ICD defines the Mission requirements and interfaces between Customer and SpaceX systems.
	Released Payload electrical interface pinout worksheet	Documentation capturing the electrical interfaces of the Payload to the Launch Vehicle and documenting the end-to-end pin-out of the SpaceX and Customer built harnessing, including electrical characteristics of each pin.
Mission Integration Analyses	SpaceX-built harness routing CAD model	SpaceX provides the Customer with a CAD model of the SpaceX-built harnessing.
	Trajectory analysis results, including collision avoidance and Monte Carlos	SpaceX will develop a nominal trajectory optimized for the Mission. This nominal trajectory will be used to determine the nominal injection state vector, develop the Launch Window, and define the Mission level deploy order and timeline. SpaceX will conduct a Monte Carlo analysis to formally quantify dispersions on the injection orbit and Launch Vehicle performance. These Monte Carlo results will serve as the verification for orbit injection accuracy requirements. This analysis includes collision avoidance.
	Verification of Launch Vehicle compliance to Loads	SpaceX confirms to Customer that the Launch Vehicle is compliance to the Loads MPE defined in Section 3.3.
	Verification of Payload clearance	SpaceX confirms clearance of the Payload using the Customer provided CAD model defined in Appendix C to the allowable Payload allowable volume defined in Appendix A.
Launch Campaign Readiness Review	Payload separation analysis results (if required)	Results of the separation analysis predicting the maximum linear and angular separation rates of the Payload upon separation from the Launch Vehicle. CubeSat deployments from Containerized deployers are not analyzed by SpaceX.
	ICD revision for signature	Revision of the ICD to be signed by the Parties, having mutually reviewed and agreed to the content.
	ICD compliance matrix and status	Verification status/evidence sorted by verification article in accordance with the approved verification matrix within the ICD, including status for all open deliverables.
	Launch integration schedule (update)	Updated and refined schedule of Launch Site operations identifying Payload stand-alone activities and combined Payload/Launch Vehicle operations.
	Launch campaign plan (update)	Updated plan for Payload arrival, integration and Launch, including the facilities to be used and the operations to be performed for both Launch Vehicle and Payload processing.
Launch Campaign	Launch campaign planning checklist (update)	Updated Launch campaign planning checklist to track Launch campaign documentation, GSE shipment list, Customer personnel attendance, Payload details related to Launch Site operations, an OPM email distribution list, and Launch campaign action items.
	Launch campaign arrival briefing	Briefing to the Customer providing information about working at the Launch Site, including contact information, security, SpaceX policies, transportation, medical, facility overview, hazardous operations and natural hazards (e.g. lightning), and personnel safety, reinforcing the training material Customer personnel completed prior to arrival at the Launch Site.
	Hazardous operations planning meetings (if required)	If required, a meeting to plan and coordinate any hazardous operations that the Payload must undergo at the Launch Site.
	Electrical checkout results (if required)	If Customer is accessing the payload after encapsulation through the umbilical harness, SpaceX provides documentation detailing the results of the SpaceX electrical checkouts performed on the harnessing which interfaces with the Payload.
	Daily Launch campaign schedule updates	Daily updates to the Launch Campaign schedule as coordinated in real time with the Customer.
	Facility environmental reports	Reports of facility temperature, relative humidity and particle count are provided to the Customer point of contact.
Post Launch	Launch Vehicle readiness certificate	Signed confirmation from SpaceX to the Customer that the Launch Vehicle is ready for countdown and Launch, obtained after a Launch Readiness Review between SpaceX and the Range.
	Orbit injection report	Provides operational state vector information, based on best available telemetry during the flight. This state vector will be provided in the SpaceX-defined format (reference Appendix E). Customer is solely responsible for conversion, if necessary, of the data into a Customer-preferred format.



**Table G-2: Customer Deliverables Description**

Milestone	Customer Deliverables	Description
Contract Signature	Technical point(s) of contact	Identification for the Customer point of contact that will interface with the SpaceX mission manager.
Mission Integration Kickoff	Completed TAA questionnaire or Export Compliance Agreement	Representations and certifications from Customer for Technical Assistance Agreement (TAA) application (if not already completed prior to the Kickoff) or signed Export Compliance Agreement.
	Completed Payload configuration worksheet	Preliminary information regarding the Payload provided by the Customer for SpaceX use in support of program deliverables including the list of Payload Constituents (in accordance with the details in Appendix H).
Mission Integration Analysis Inputs	Payload inputs to ICD	Payload interface information and system descriptions to be captured in the ICD format provided by SpaceX; tracked changes to the template are preferred.
	Payload CAD model	Payload CAD model, in accordance with Appendix C.
	Payload dynamic model and worksheet	Payload dynamic model, in accordance with Appendix B and accompanying dynamics model worksheet.
	Payload mass properties	Current best estimate of the Payload mass properties (mass, center of mass, moments of inertia) using the worksheet provided by SpaceX. Reasonable uncertainty bounds are highly encouraged.
	Payload separation system properties	Customer inputs describing the Payload separation system mechanical properties including spring, switch, and connector locations and separation energy using the SpaceX provided worksheet.
	Payload separation verification analysis	Customer provides an analysis verifying that Payload Constituents deployed from the Launch Vehicle are packaged in such a way to meet the separation requirements outlined in Section 2.4.
	Payload transmitter verification	Customer verification that Payload transmitter turn on times are compatible with Launch Vehicle frequency restrictions using the SpaceX provided worksheet.
	Payload electrical interface pinout worksheet	Customer inputs provided in the SpaceX provided template that defines the Launch Vehicle to Payload electrical harness properties and pin-outs.
	Payload environmental test approach and schedule	Provide the test approach compared to Section 3.4 for each Payload Constituent using the SpaceX provided worksheet, including additional rationale for any requests for deviation to the requirements found in Section 3.4.
L-6 M Range Safety Submissions	Propulsion system details (if required)	Customer provides SpaceX with propulsion system details for SpaceX evaluation in accordance Section 4.1.5 if applicable to the Payload.
	Rideshare Range Safety checklist	A checklist defining the Payload design and hazardous subsystems. For subsystems, depending on complexity and hazard level, additional documentation may be required by the Range, such as 91-710 Tailoring, Missile System Prelaunch Safety Packages (MSPSP), and certification data for hazardous systems.
Launch Campaign Planning	Program Introduction	A simplified and high-level overview of the Payload and its associated hazardous systems in a condensed format for Launch Range safety authorities (template provided by SpaceX). The Program Introduction provides quick reference on Payload appearance, size, mass, propellants, batteries, pressure vessels, heat pipes, and radiating sources.
	Initial inputs to launch campaign checklist	Customer inputs to the launch campaign checklist including status for launch campaign documentation, GSE shipment list, Customer personnel attendance, Payload details related to Launch Site operations, and OPM email distribution list.
	Initial inputs to launch campaign daily schedule	Description of Customer Launch Site activities required in the launch campaign daily schedule for Payload stand-alone processing.
	CAD for lifting GSE for joint mating operations	CAD model of the Customer-provided lifting GSE that will be used for the final mate of the Payload to the Launch Vehicle, after Customer has mated the Payload to the SpaceX-provided Mechanical Interface (if applicable) described in Section 4.2.4.
	Summary concept of operations for joint mating operations	Summary of the concept of operations for the joint mating procedure of the Payload to the Launch Vehicle including images and simplified descriptions when appropriate.
Mission Integration	List of emails for launch site badging access	Customer provided list of emails for potential launch site personnel in order to fill out badge access paperwork online.
	Customer-built harness routing CAD model	Customer provides SpaceX with a CAD model of the Customer-built harnessing.



Milestone	Customer Deliverables	Description
L-4 M Range Safety Submissions	Group Operating Plan (GOP)	The Payload Ground Operations Plan (GOP) provides a detailed description of the hazardous and safety critical operations associated with the Payload and its GSE. The Payload GOP contains a description of planned operations and the hazard analysis of those operations. The Customer's GOP must be prepared in accordance with 91-710 Vol 6, attachment 1 for SpaceX to submit to the Launch Range safety authority for review and approval.
	AFSPCMAN 91-710 Tailoring (if required)	Tailoring provides a means for formulating a Payload-specific edition of AFSPCMAN 91-710 (Volumes 1, 3, and 6) and documents whether or not the Customer will meet applicable safety requirements as written or achieve an equivalent level of safety through a requested and approved alternative approach. The Customer's tailoring requests must be prepared in accordance with 91-710 Vol 1, attachment 1 for SpaceX to submit to the Launch Range safety authority for review and approval.
	Mission System Prelaunch Safety Package (if required)	Payload safety information providing the Launch Range safety authority with a description of hazardous and safety-critical support equipment and flight hardware associated with the Payload. The Customer's MSPSP must be prepared in accordance with 91-710 Vol 3, attachment 1 for SpaceX to submit to the Launch Range safety authority for review and approval.
	Certification Data for Hazardous Systems (if required)	Certification data for Payload hazardous systems. A system is deemed hazardous if it includes any of the following: pressure vessels (over 100 psid), batteries, hazardous materials, non-ionizing and ionizing radiation systems, hazardous propulsion systems, or ordnance. Data must also be provided for GSE (for example, lift slings).
Final Mission Integration Analysis Inputs	Payload mass properties (final update)	Customer to provide SpaceX refined Payload mass properties inputs for the Monte Carlo analysis of the nominal trajectory using the Payload mass properties template provided by SpaceX. Updates must fall within previously provided uncertainty bounds.
	Payload environmental verification report	Customer to provide to SpaceX final environmental verification test and/or analysis results in order to show compliance to Section 3.4 and in accordance with the SpaceX approved Payload environmental test approach. Customer must use the Payload environmental verification report template provided by SpaceX to summarize data into a single report.
L-2 M Range Safety Submissions	AFSPCMAN 91-710 Compliance Letter	Signed confirmation from Customer that the Payload complies with all safety requirements.
	Ground Operating Plan defined Hazardous procedures	Payload procedures provide detailed, systematic descriptions of the manner in which Customer's hazardous and safety critical operations will be accomplished at the Launch Site. These procedures are the basis from which approval to start hazardous or safety critical operations are obtained from the Launch Range safety authority. The Customer's hazardous procedures must be prepared in accordance with 91-710 Vol 6, attachment 2 for SpaceX to submit to the Launch Range safety authority for review and approval. Customer is strongly encouraged to deliver procedures earlier than 45 days before hardware arrival at the Launch Site. Procedures must be in English.
Mission Integration Analyses	CubeSat(s) environmental verification report (if applicable)	Customer to provide to SpaceX final environmental verification test and/or analysis results for independently tested CubeSats (if applicable) in order to show compliance to Section 3.4 and in accordance with the SpaceX approved Payload environmental test approach. Customer must use the Payload environmental verification report template provided by SpaceX to summarize data into a single report.
Launch Campaign Readiness Review	Final inputs to launch campaign checklist	Customer final inputs to the launch campaign checklist including status for launch campaign documentation, GSE shipment list, Customer personnel attendance, Payload details related to Launch Site operations, and OPM email distribution list.
	Final inputs to launch campaign daily schedule	Customer final inputs describing Launch Site activities required in the launch campaign daily schedule for Payload stand-alone processing.
	Badging details filled out via Customer Portal	Customer details including personal information, and passport/visa scans and photos necessary for access to the Launch Site badging completed online.
	Completed licensing and insurance information template	Customer provides the Hazardous Materials list in support of SpaceX's application of an FAA license for the mission as well as crosswaivers inputs. If applicable, evidence of insurance for the Payload, including identification of insurer point of contact and if Customer has procured Payload insurance, Customer to provide evidence of express waivers of subrogation as to SpaceX and its Related Third Parties. If applicable, Customer identifies any parties that would like to be listed as additional insured on the SpaceX procured third party liability insurance.
Payload Shipment and Arrival	Payload licensing certification letter	Signed confirmation from Customer to SpaceX, in the form of the letter shown in Appendix F that required Payload licensing is in place and that the information provided to licensing agencies and SpaceX is accurate. The letter must be provided to SpaceX prior to Payload shipment to the Launch Site.
	Copies of all required on-orbit Payload licenses	Customer to provide proof of all required on-orbit licensing required for Payload Constituents to legally operate on orbit.



Milestone	Customer Deliverables	Description
	Launch site awareness training complete	All Customer personnel participating in the Launch Campaign complete online Launch Site awareness training prior to arrival at the Launch Site.
Launch Campaign	Payload measured mass (joint operation with SpaceX)	Measured Payload mass, including adjustments for any non-flight items (e.g. remove-before-flight covers) which remained on the Payload during the final lift to Launch Vehicle hardware during joint mating operations with SpaceX.
	Payload encapsulation readiness certificate	Signed confirmation from Customer to SpaceX that the Payload is ready for fairing encapsulation, in the form of the letter shown in Appendix D.
	Payload launch readiness certificate	Signed confirmation from Customer to SpaceX that the Payload is ready for countdown and Launch, in the form of the letter shown in Appendix D.
Post Launch	Coordination with space situational agency	Customer coordination for space object identification as described in Section 6.5.7.
	Payload operations status	Brief summary of the current Payload status, as well as an early operations summary, if available.



## APPENDIX H: PAYLOAD CONSTITUENTS

SpaceX will provide a document template requesting the information defined in Table H-1.

**Table H-1: Payload Constituent Details**

<b>Payload Constituent (satellite, separation system, etc.)</b>	<b>Constituent #1</b>	<b>Constituent #2</b>	<b>Constituent # XX</b>
Owner			
Address (including Country) of Owner			
Manufacturer			
Address (including country) of Manufacturer			
Operator			
Address (including country) of Operator			
End User			
Address (including country) of End User(s)			
Delivery on Orbit User			
Delivery on Orbit User Address			
End Use			
General Description			
Propulsion System & Type			
CubeSat Size (i.e. #U) if applicable			
Quantity of Constituents within Payload			

SpaceX may approve or deny one or more of the requested Payload Constituents, including if SpaceX determines it is unable to obtain regulatory approvals. Customer is allowed to propose an alternate Payload Constituent in place of any rejected Payload Constituent. After Mission integration analyses have begun SpaceX may reject a proposed alternate Payload Constituent if the proposed Payload Constituent invalidates the Mission integration analyses (as determined by SpaceX) or invalidates any licensing or regulatory approvals. SpaceX's approval is at the sole discretion of SpaceX while timely approval for all items within the Payload be the sole responsibility of the Customer. Customer's failure to receive approval for any item within the Payload may result in rebooking and associated fees.



## APPENDIX I: OPTIONAL SERVICES

SpaceX offers the optional services described in this section for an additional cost above the baseline pricing found at [www.spacex.com/rideshare](http://www.spacex.com/rideshare).

**Table I-1: Optional Services**

Service	Description
Payload Adapter Plate	SpaceX can provide an adapter plate for Payloads with mechanical interfaces other than 8", 15" or 24" at the Customer request. The Payload adapter plate can accommodate mechanical interface diameters including 11.732", 13", and 18.25". Other Payload mechanical interfaces may be considered, please contact SpaceX for further details. See <a href="http://www.spacex.com/rideshare">www.spacex.com/rideshare</a> for adapter plate pricing details.
Separation System	SpaceX can provide a separation system for Payloads at the Customer request. Separation systems vary in price depending on the size of the system and require at least a 6-month lead-time for procurement. See <a href="http://www.spacex.com/rideshare">www.spacex.com/rideshare</a> for separation system pricing details.
Launch Site Fueling	Standard Rideshare Launch services do not include provisions for Payload fueling at the Launch Site. Customer may perform fueling operations at the Launch Site that do not require SCAPE, for an additional cost, which includes an additional day of processing at the Launch Site. See <a href="http://www.spacex.com/rideshare">www.spacex.com/rideshare</a> for pricing details. For any fueling operations that do require SCAPE, please contact SpaceX for further information.
Payload Electrical Connectivity	SpaceX accommodates electrical connectivity between Customer EGSE and the Payload prior to mating the Payload to Launch Vehicle hardware. SpaceX can provide electrical connectivity between Customer EGSE and the Payload in the Hangar after transport from the PPF and on the Pad after rollout until T-1 hour including allocation of a customer console for remote monitoring after as an optional service. Contact SpaceX for pricing details.
Additional Electrical Channels	The standard electrical interface offering for Rideshare Plates is for a single deployment event. Additional channels of primary deployment, secondary deployment, breakwire signals, and in some cases, up to one (1) additional umbilical group are available as an optional service. Contact SpaceX for details.
Insurance	SpaceX can provide, at Customer's request, optional Launch-only insurance for the Payload and the cost of Launch. Contact SpaceX for details.





## APPENDIX J: DEFINITIONS

"**Agreement**" refers to the Launch Services Agreement between SpaceX and Customer.

"**Acceptance of Request**" means the email sent to Customer by SpaceX upon acceptance of the Request for Launch Services submitted by Customer. The Acceptance of Request documents and becomes a part of SpaceX's acceptance of the Agreement between SpaceX and Customer.

"**Co-Payload**" means a payload of a customer of SpaceX, other than Customer, that is manifested on the same Mission as Customer.

"**Co-Payload Customer**" means any customer of SpaceX other than Customer that has a payload manifested on the same Mission as Customer.

"**CSLA**" means the Commercial Space Launch Act of 1988, as amended, 51 U.S.C. §§ 50901-50923 and the regulations issued pursuant thereto, including the Commercial Space Transportation Regulations, 14 C.F.R. Parts 400-460.

"**Customer**" has the meaning set forth in the Acceptance of Request signature page of the Agreement.

"**Dedicated Rideshare**" means a Mission with only Rideshare Payloads as defined in this document.

"**EAR**" means the Export Administration Regulations administered by the Bureau of Industry and Security, U.S. Department of Commerce, 15 C.F.R. Parts 730-744, pursuant to the Export Control Reform Act of 2018.

"**Excusable Delays**" shall mean a delay arising from causes beyond the control of the affected party, including acts of god or government (except to the extent such acts are undertaken by the government that owns or controls a party or of which a party is a part), terrorism, riot, revolution, hijacking, fire, embargo, sabotage, Launch Range 'no go' determinations or unavailability, or priority determinations by the US Government under the Defense Priorities and Allocations System (15 CFR Part 700).

"**Form of FAA Cross-Waiver**" means as found in Appendix B to 14 CFR Part 440 at the following hyperlink: <http://www.ecfr.gov/cgi-bin/text-idx?rgn=div5&node=14:4.0.2.9.22#14:4.0.2.9.22.1.30.12.33>. In the event this link is ever deactivated, the Form of Cross Waiver will be the most recent Form of Cross-Waiver published in the US Code of Federal Regulations.

"**Intentional Ignition**" means when the ignition command is given for purposes of Payload carriage causing ignition of the first-stage engines of the Launch Vehicle.

"**Interface Control Document (ICD)**" means that document which will be prepared by SpaceX with data to be supplied by Customer, negotiated in good faith and mutually agreed upon in writing by both Parties prior to the beginning of the Launch Period. The Interface Control Document will supersede any interface requirements document.

"**ITAR**" means the International Traffic in Arms Regulations administered by the Directorate of Defense Trade Controls, U.S. Department of State, 22 C.F.R. Parts 120-130, pursuant to the Arms Export Control Act of 1976, as amended, 22 U.S.C. § 2778.

"**Launch**" means Intentional Ignition followed by either: (a) Lift-Off or (b) the loss or destruction of the Payload or the Launch Vehicle (or both).

"**Launch Campaign**" means the activities and discussions leading up to and including Payload to Launch Vehicle integration at the Launch Site through Launch.

"**Launch Complex**" means the SpaceX-operated facility where the Launch Vehicle is integrated and from which the Launch Vehicle is launched.

"**Launch Date**" has the meaning set forth in Section 6.6.1. If the Launch Date has not yet been established in accordance with Section 6.6.1, the Launch Date will be deemed the first day of the Launch Period.

"**Launch Period**" has the meaning set forth in the Agreement.

"**Launch Range**" means the U.S. Governmental authorities and office with jurisdiction over the Launch Site.

"**Launch Services**" means those services described in this document to be performed by SpaceX.

"**Launch Site**" means the SpaceX launch facility at Cape Canaveral Air Force Station or another SpaceX launch facility capable of supporting the Launch Services, as determined by SpaceX.



**"Launch Vehicle"** means a launch vehicle capable of achieving Customer's orbital parameter requirements as set forth in the Agreement, and refers to the Falcon 9 Launch Vehicle in this document.

**"Launch Window"** means the time period established by SpaceX during which the Launch is scheduled to occur on the Launch Date.

**"Licenses"** means all licenses, authorizations, clearances, approvals and permits necessary for each Party to carry out its respective obligations under the Agreement. Each Party agrees to provide reasonable assistance to the other Party as necessary to obtain such Licenses.

**"Lift-Off"** means release of the hold-down restraints and physical separation of the Launch Vehicle from the launch pad.

**"Material Breach"** means a breach in which the non-breaching party did not receive the "substantial benefit" of the bargain under the Agreement. To exercise its right to terminate for Material Breach, Customer shall notify SpaceX of this election to terminate in writing and within thirty (30) days following the conclusion of the ninety (90) day cure period. For the sake of clarity, neither (i) a delay nor ii) a Launch or Launch Activities resulting in the loss or destruction of the Payload, shall be deemed a Material Breach by SpaceX hereunder, and except as expressly stated in the Termination section of the Terms and Conditions, nothing in this Agreement shall be construed in any way as obligating SpaceX to refund any payment made in connection with any Launch Services performed hereunder.

**"Mechanical Interface"** means the SpaceX provided structural interface utilized to mechanically mate the Payload to the Launch Vehicle hardware.

**"Mission"** means the services and deliverables to be provided by both SpaceX and Customer to perform a Launch of the Payload, with an initial Launch-ready mass and orbit parameters defined in the Agreement.

**"Parties"** means Customer and SpaceX.

**"Party"** means Customer or SpaceX.

**"Payload"** means the Customer provided integrated spacecraft, adapters, separation systems, harnessing, and avionics to be launched in accordance with the parameters set forth in the Acceptance of Request. The Payload may not contain any Payload Constituents provided by the Customer without the written mutual agreement of SpaceX.

**"Payload Constituent"** means (a) spacecraft, payload, instrument, experiment, or similar equipment that is integrated onto or into the Payload, but is not an integral part of the Payload, including but not limited to CubeSats, small satellites, and hosted payloads; and (b) any integrated dispenser, separation system, or other significant hardware that are contained within the Payload.

**"Primary Payload"** means a satellite independently contracted with SpaceX that does not meet the definition of a Rideshare Payload as defined in this document.

**"Registration Convention"** shall mean the Convention on Registration of Objects Launched into Outer Space, done Nov. 12, 1974 (opened for signatures Jan. 14, 1975), 28 U.S.T. 695, T.I.A.S. No. 8480, 1023 U.N.T.S. 15.

**"Related Third Parties"** means (a) the Parties' and Co-Payload Customer(s)' respective contractors and subcontractors involved in the performance of this Agreement and their respective directors, officers, employees, and agents; (b) the Parties' and Co-Payload Customer(s)' respective directors, officers, employees, and agents; and (c) any entity or person with any financial, property or other material interest in the Payload, Co-Payload(s), the Launch Vehicle or the GSE.

**"Secondary Rideshare"** means Rideshare Payloads that are paired on the same Mission as a Primary Payload.

**"SpaceX Account"** means the account to which Customer shall make payments to SpaceX, as notified by SpaceX from time to time, within a reasonable time to make such payments.

**"Standard Offering Bulkhead"** means the Launch Vehicle side electrical interface Customer built Payload harnessing will connect to consisting of two separation signal connectors and one umbilical connector.

**"Starlink"** means the satellite constellation operated by SpaceX and launched onboard SpaceX Launch Vehicles.

**"Terminated Ignition"** means Intentional Ignition not followed by Launch.